



TIMBER NOTICE OF SALE

SALE NAME: BEIGNET

AGREEMENT NO: 30-105182

AUCTION: June 12, 2024 starting at 10:00 a.m., COUNTY: Snohomish Northwest Region Office, Sedro Woolley, WA

SALE LOCATION: Sale located approximately 9 miles east of Arlington, WA.

PRODUCTS SOLD AND SALE AREA:

All timber bounded by white timber sale boundary tags, adjacent young stands, and the EB-ML and EB-40 roads, except cedar salvage (cedar snags, preexisting dead and down cedar trees and cedar logs), trees marked with blue paint on the bole and root collar, and forest products tagged out by yellow leave tree area tags in Unit #1 (collectively labeled 1A and 1B).

All timber bounded by white timber sale boundary tags, adjacent young stands, and the EB-ML Road, except cedar salvage (cedar snags, preexisting dead and down cedar trees and cedar logs), trees marked with blue paint on the bole and root collar, and forest products tagged out by yellow leave tree area tags in Unit #2.

All timber bounded by white timber sale boundary tags and adjacent young stands, except cedar salvage (cedar snags, preexisting dead and down cedar trees and cedar logs), trees marked with blue paint on the bole and root collar, and forest products tagged out by yellow leave tree area tags in Unit #3.

All timber bounded by white timber sale boundary tags, adjacent young stands, and the EB-ML, EB-12, EB-1215 and EB-1215-03 roads, except cedar salvage (cedar snags, preexisting dead and down cedar trees and cedar logs), trees marked with blue paint on the bole and root collar, and forest products tagged out by yellow leave tree area tags in Unit #4 (collectively labeled 4A and 4B).

All timber bounded by orange right-of-way tags.

All forest products above located on part(s) of Sections 30 all in Township 32 North, Range 7 East, Sections 13, 14, 23, 24, 25, 26 and 35 all in Township 32 North, Range 6 East, W.M., containing 129 acres, more or less.

CERTIFICATION: This sale is certified under the Sustainable Forestry Initiative® program Standard (cert no: BVC-SFIFM-018227)

ESTIMATED SALE VOLUMES AND QUALITY:

Table with columns: Species, Avg DBH, Ring Count, Total MBF, and MBF by Grade (1P, 2P, 3P, SM, 1S, 2S, 3S, 4S, UT). Rows include Douglas fir, Hemlock, Red alder, Cottonwood, Redcedar, and Sale Total.

MINIMUM BID: \$0.00 BID METHOD: Sealed Bids



TIMBER NOTICE OF SALE

- SPECIAL REMARKS:**
1. Harvest was planned to be 100% ground-based.
 2. HQ DF noted within the sale area. See cruise for further details.
 3. Douglas-fir poles were noted within the sale area.
 4. Extreme Hazard Abatement (Clause S-020) is required for harvest activities near the Ebey Mountain Road.
 5. EB-Temp road to be abandoned at the start of operations.
 6. Dust abatement on the EB-ML road shall be in the form of Lignin Sulfonate. See road plan for further details.

DRAFT

TIMBER SALE MAP

SALE NAME: BEIGNET
AGREEMENT #: 30-105182
TOWNSHIP(S): T32R6E, T32R7E
TRUST(S): Common School and Indemnity (3), State Forest Transfer (1)

REGION: Northwest Region
COUNTY(S): Snohomish
ELEVATION RGE: 600-1640

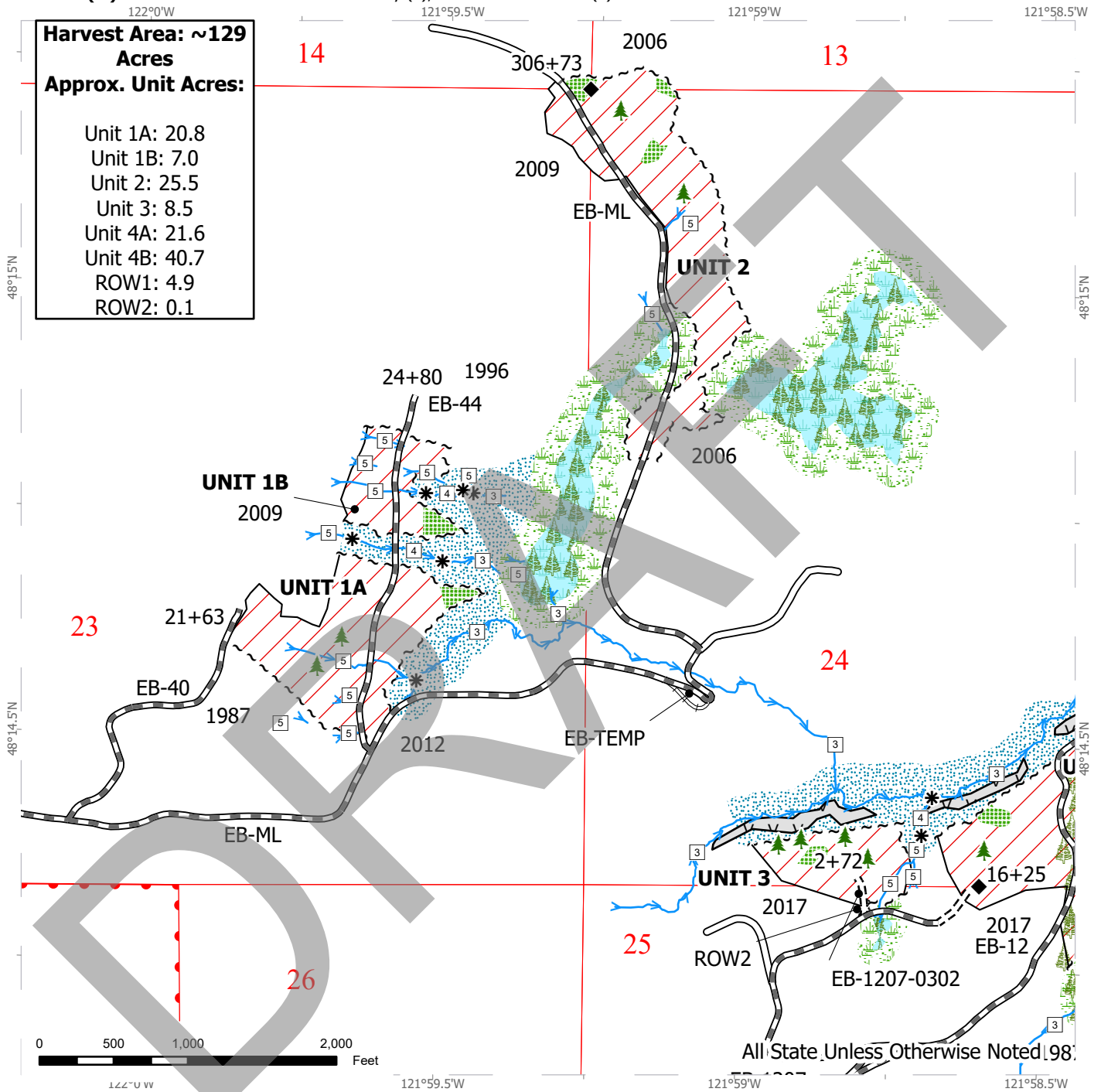

Variable Retention Harvest	Right of Way Tags	Streams
Leave Tree Area	Timber Type Change	Stream Type
Forested Wetland	DNR Managed Lands	Stream Type Break
Wetland Mgt Zone	Existing Roads	Leave Tree Area <1/4-acre
Riparian Mgt Zone	Required Pre-Haul Maintenance	Survey Monument
No-Entry Zone	Required Construction	
Sale Boundary Tags	Required Reconstruction	



TIMBER SALE MAP

SALE NAME: BEIGNET
AGREEMENT #: 30-105182
TOWNSHIP(S): T32R6E, T32R7E
TRUST(S): Common School and Indemnity (3), State Forest Transfer (1)

REGION: Northwest Region
COUNTY(S): Snohomish
ELEVATION RGE: 600-1640

Harvest Area: ~129 Acres
Approx. Unit Acres:

- Unit 1A: 20.8
- Unit 1B: 7.0
- Unit 2: 25.5
- Unit 3: 8.5
- Unit 4A: 21.6
- Unit 4B: 40.7
- ROW1: 4.9
- ROW2: 0.1

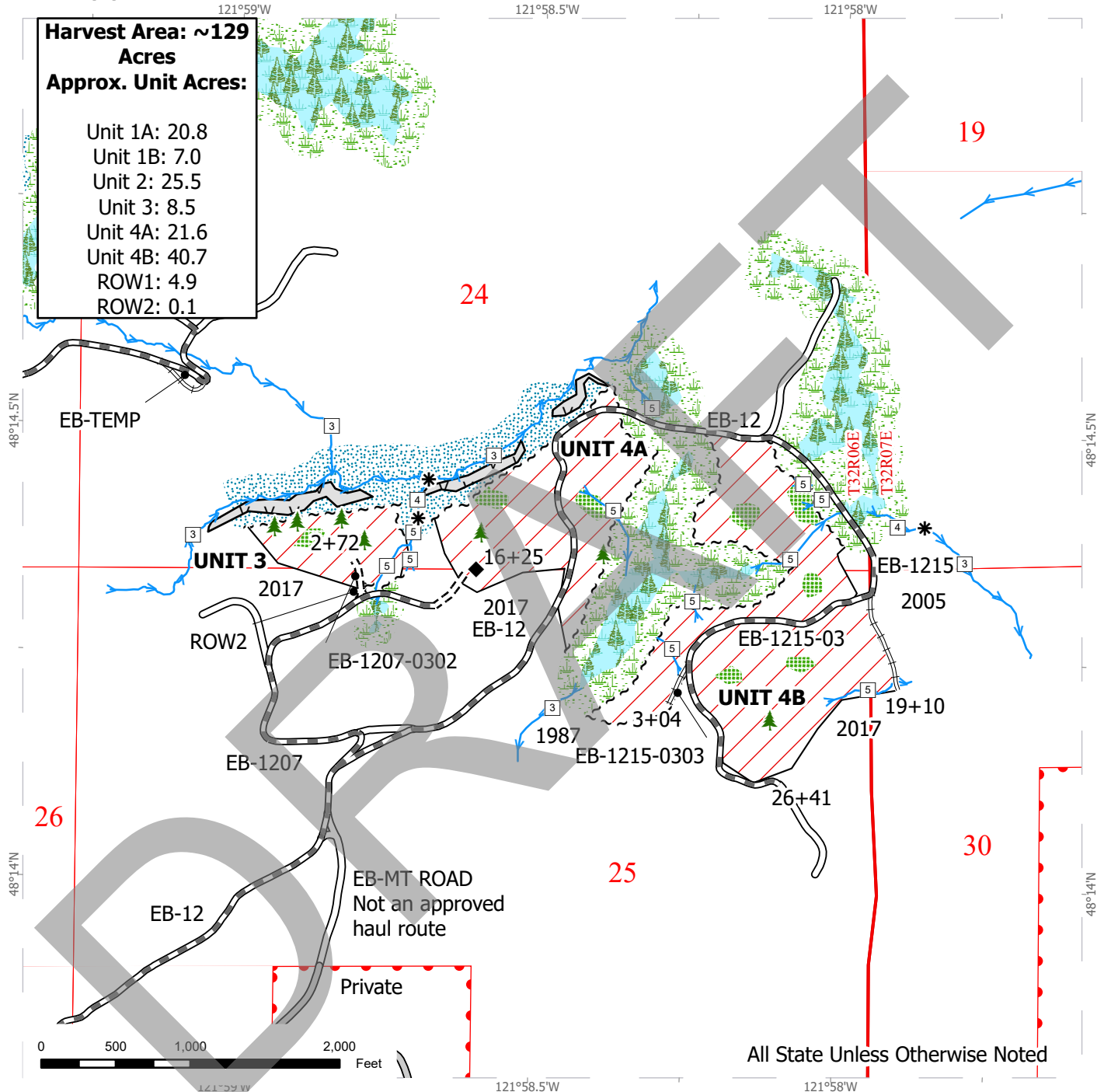

All State Unless Otherwise Noted

Variable Retention Harvest	Right of Way Tags	Required Reconstruction
Leave Tree Area	Timber Type Change	Streams
Forested Wetland	DNR Managed Lands	Stream Type
Wetland Mgt Zone	County Road	Stream Type Break
Riparian Mgt Zone	Existing Roads	Leave Tree Area <1/4-acre
No-Entry Zone	Required Pre-Haul Maintenance	Survey Monument
Sale Boundary Tags	Required Construction	



TIMBER SALE MAP

SALE NAME: BEIGNET
AGREEMENT #: 30-105182
TOWNSHIP(S): T32R6E, T32R7E
TRUST(S): Common School and Indemnity (3), State Forest Transfer (1)

REGION: Northwest Region
COUNTY(S): Snohomish
ELEVATION RGE: 600-1640

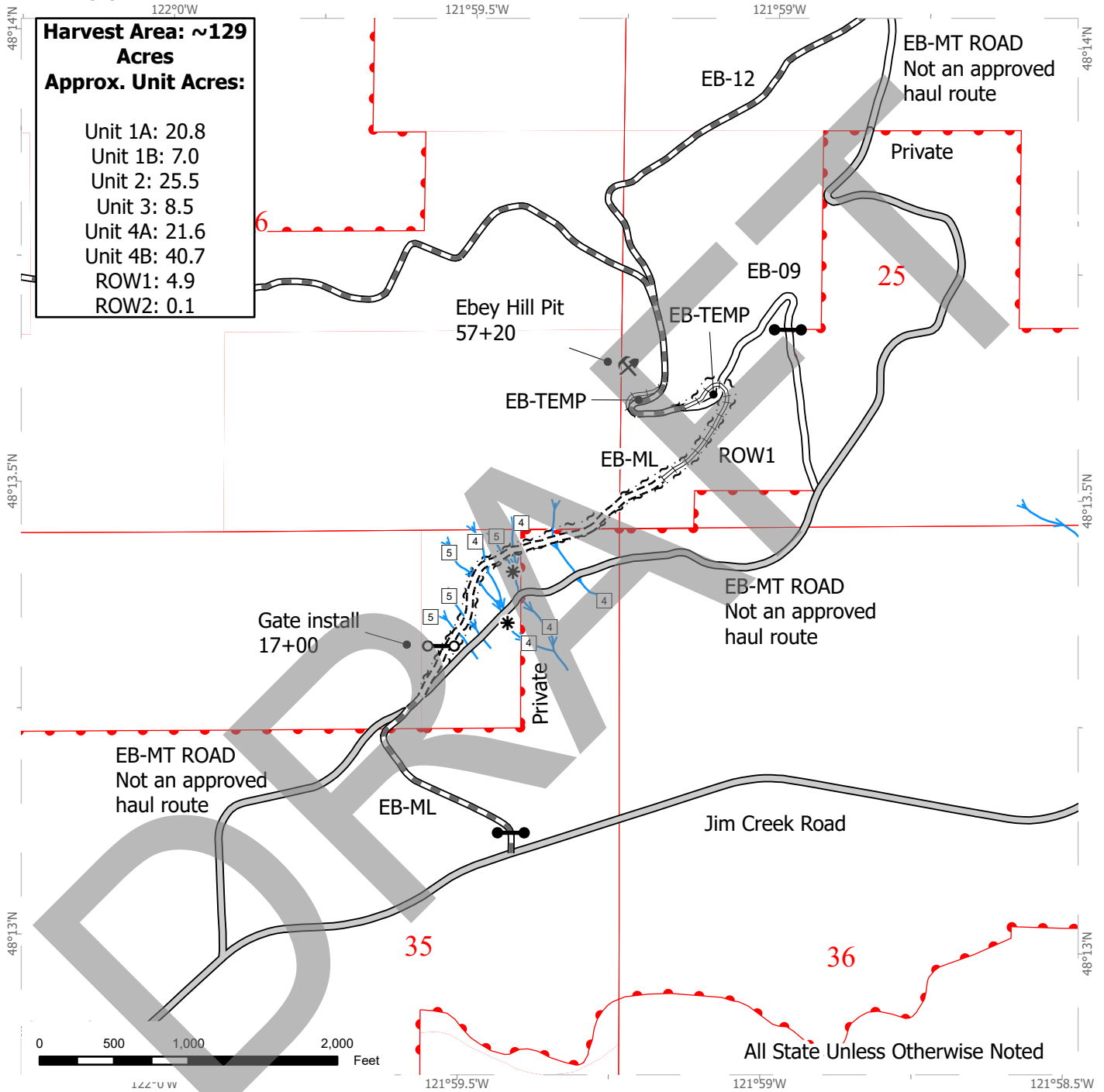

~ ~ Right of Way Tags	Streams
DNR Managed Lands	Stream Type
County Road	Stream Type Break
Existing Roads	Rock Pit
Required Pre-Haul Maintenance	Gate (F 1-3)
Required Construction	Gate Installation
Required Reconstruction	



DRIVING MAP

SALE NAME: BEIGNET
AGREEMENT #: 30-105182
TOWNSHIP(S): T32R6E, T32R7E
TRUST(S): Common School and Indemnity (3), State Forest Transfer (1)

REGION: Northwest Region
COUNTY(S): Snohomish
ELEVATION RGE: 600-1640

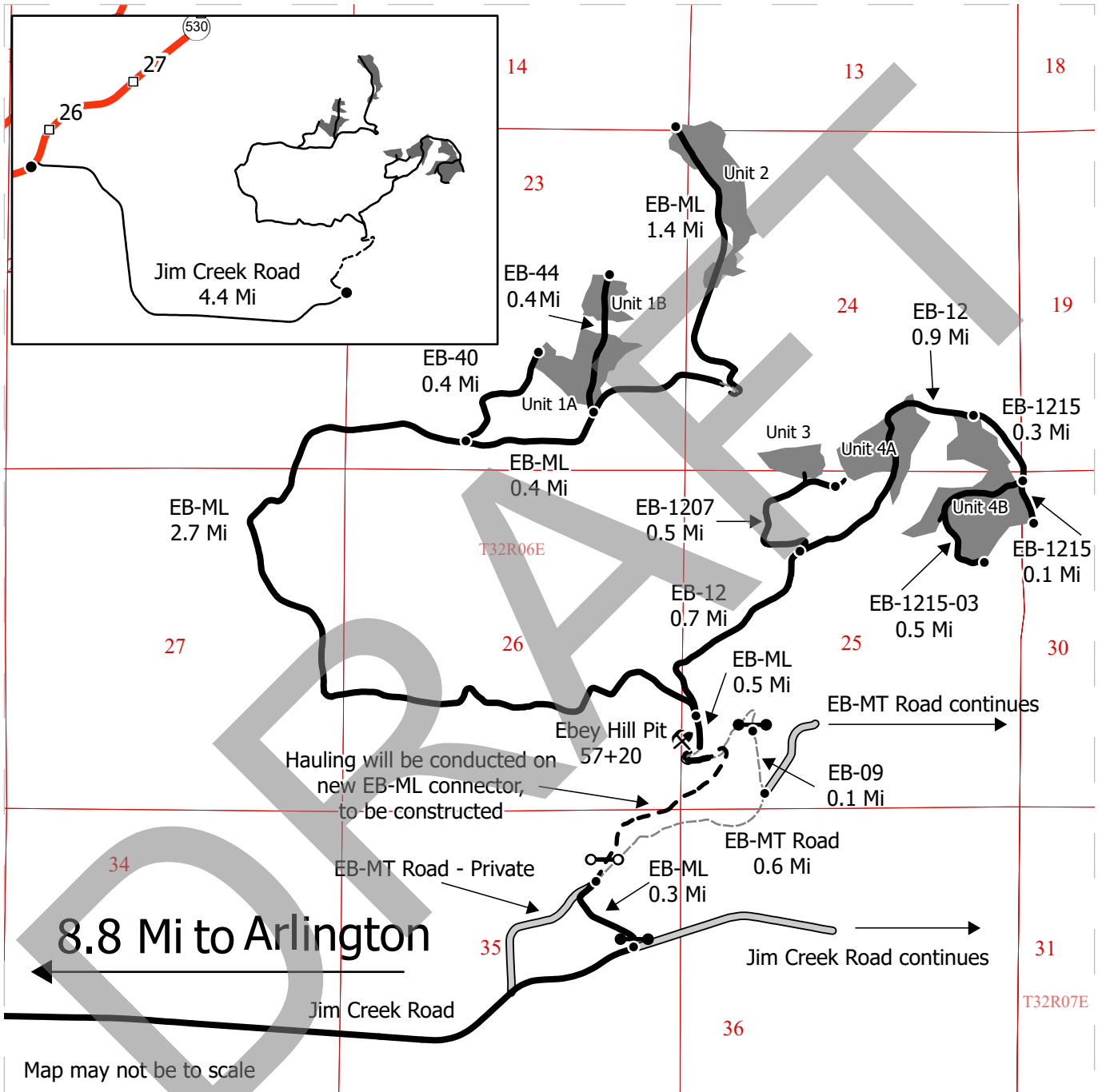

- Harvest Unit
- County Road
- Haul Route
- View Only Route
- New Construction
- Distance Indicator
- Gate (F 1-3)
- Gate Installation
- Rock Pit

DRIVING DIRECTIONS:

From the Highway 9/State Route 530 NE intersection in Arlington, travel 4.4 miles northeast on State Route 530. Turn right onto Jim Creek Road. Travel 4.4 miles east on Jim Creek Road. Turn left onto the EB-ML; F 1-3 key required. Continue 0.3 miles to the junction of EB-ML and EB-MT Road. Continue on EB-MT Road for 0.6 miles, then turn left onto EB-09. After 0.1 miles, pass the gate; F 1-3 key required. To access units 3, 4A, and 4B, continue for 0.5 miles. Turn right at the fork onto the EB-12. After 0.7 miles, turn left onto EB-1207 to access unit 3. For unit 4A, continue on EB-12 for 0.9 miles beyond the EB-1207 fork. To access unit 4B, continue on EB-1215 for 0.3 miles. Unit is located on the right. To access units 1A, 1B, and 2, turn left at the EB-12 fork. Continue on the EB-ML for 3.1 miles. Turn left onto the EB-44 to access units 1A and 1B. Otherwise, continue on the EB-ML for 1.4 miles to access unit 2.



Timber Sale Cruise Report Beignet - NW

Sale Name: BEIGNET

Sale Type: LUMP SUM

Region: NORTHWEST

District: CASCADE

Lead Cruiser: Matt Llobet

Other Cruisers: Bailey Vos

Cruise Narrative:

Beignet is a four unit timber sale located 4.4 miles east of Arlington, off the EB-ML. The sale ranges from 1054 feet to 1550 feet in elevation. Forest roads provide good road access throughout all four units.

All VHR units were cruised using a 54.4/40 BAF and a 1:1 sample ratio was applied. The right of way units were cruised using a 54.4/40.0 BAF and a cruise-all sample was applied. The smallest merchantable tree cruised throughout the sale had a DBH of 7.0 inches and 5.0 inches at 16 feet.

Conifer log lengths were cruised in 2 foot multiples - maximizing 32-40 ft. lengths.
Hardwood log lengths were cruised in 10 foot multiples - no longer than 30 feet long.

The stand characteristics throughout Beignet showed a uniform Douglas fir (79%) dominant timber type with scattered Western Hemlock (18%) throughout. The terrain showed productive harvesting ground throughout all four units. Beignet cruised out at 35,281 bf per acre and all timber showed good form. Portions of Beignet carry a dense WH understory with thick brush, which made sighting stems on plot difficult. Douglas fir poles (71mbf) were cruised throughout the sale, in both transmission and distribution lengths.

Right of Way:

The right of way volume associated with Beignet is fully timbered new construction.

Logging:

Approximately 100% of the sale is ground base harvest with productive operator ground.

Timber Sale Notice Volume (MBF)

Sp	DBH	Rings/In	Age	MBF Volume by Grade				
				All	2 Saw	3 Saw	4 Saw	Utility
DF	19.0	8.0		3,619	1,799	1,633	170	18
WH	19.0			825	493	284	47	1
RA	12.4			76	3	25	47	
BC	21.7			27	26		1	
RC	23.4			15		12	2	
ALL	18.4	8.0		4,562	2,321	1,955	267	19

Timber Sale Notice Weight (tons)

Sp	Tons by Grade				
	All	2 Saw	3 Saw	4 Saw	Utility

Sp	Tons by Grade				
	All	2 Saw	3 Saw	4 Saw	Utility
DF	26,589	12,024	12,871	1,539	155
WH	6,823	3,611	2,742	454	16
RA	591	25	193	374	
BC	165	158		7	
RC	114		99	16	
ALL	34,282	15,817	15,904	2,389	171

Timber Sale Overall Cruise Statistics

BA (sq ft/acre)	BA SE (%)	V-BAR (bf/sq ft)	V-BAR SE (%)	Net Vol (bf/acre)	Vol SE (%)
231.9	4.7	153.5	1.8	35,281	5.1

Timber Sale Unit Cruise Design

Unit	Design	Cruise Acres	FMA Acres	N Plots	N Cruise Plots	N Void Plots
BEIGNET U1	B1C: VR, 1 BAF (54.44) Measure/Count Plots, Sighting Ht = 4.5 ft	27.8	31.9	20	10	0
BEIGNET U2	B2C: VR, 2 BAF (54.44, 40 for some species) Measure/Count Plots, Sighting Ht = 4.5 ft	25.5	29.1	18	10	0
BEIGNET U3	B2C: VR, 2 BAF (54.44, 40 for some species) Measure/Count Plots, Sighting Ht = 4.5 ft	8.5	9.2	9	6	0
BEIGNET U4	B2C: VR, 2 BAF (54.44, 40 for some species) Measure/Count Plots, Sighting Ht = 4.5 ft	62.3	72.0	31	17	0
BEIGNET ROW1	B1: VR, 1 BAF (40) Measure All, Sighting Ht = 4.5 ft	5.1	5.6	8	8	0
BEIGNET ROW2	B2: VR, 2 BAF (54.44, 40 for some species) Measure All, Sighting Ht = 0 ft	0.1	0.1	1	1	0
All		129.3	147.8	87	52	0

Timber Sale Log Grade x Sort Summary

Sp	Status	Grade	Sort	Dia	Len	BF Gross	BF Net	Defect %	Tons	MBF Net
BC	LIVE	2 SAW	Domestic	13.0	38	208	200	4.0	157.7	25.8
BC	LIVE	4 SAW	Domestic	5.6	30	8	8	0.0	7.2	1.0
DF	LIVE	2 SAW	Domestic	14.9	38	13,577	13,323	1.9	11,550.5	1,722.6
DF	LIVE	2 SAW	HQ-B	28.1	40	208	208	0.0	135.1	26.9

Sp	Status	Grade	Sort	Dia	Len	BF Gross	BF Net	Defect %	Tons	MBF Net
DF	LIVE	2 SAW	Pole	14.5	40	380	380	0.0	338.5	49.1
DF	LIVE	3 SAW	Domestic	9.0	37	12,597	12,460	1.1	12,709.9	1,611.1
DF	LIVE	3 SAW	Pole	9.9	40	172	172	0.0	161.0	22.2
DF	LIVE	4 SAW	Domestic	6.6	24	1,350	1,312	2.8	1,538.9	169.7
DF	LIVE	CULL	Cull	12.7	8	36	0	100.0	0.0	0.0
DF	LIVE	UTILITY	Pulp	6.5	29	137	137	0.0	155.2	17.7
RA	LIVE	2 SAW	Domestic	12.4	30	26	25	3.4	24.5	3.2
RA	LIVE	3 SAW	Domestic	10.6	28	195	195	0.0	192.5	25.2
RA	LIVE	4 SAW	Domestic	6.7	21	365	365	0.0	374.1	47.3
RC	LIVE	3 SAW	Domestic	9.8	25	99	95	4.3	98.7	12.3
RC	LIVE	4 SAW	Domestic	5.3	24	18	18	0.0	15.5	2.3
WH	LIVE	2 SAW	Domestic	14.4	39	3,839	3,811	0.7	3,610.9	492.8
WH	LIVE	3 SAW	Domestic	9.3	37	2,247	2,200	2.1	2,742.1	284.5
WH	LIVE	4 SAW	Domestic	6.3	24	361	361	0.0	453.8	46.7
WH	LIVE	CULL	Cull	15.3	10	56	0	100.0	0.0	0.0
WH	LIVE	UTILITY	Pulp	7.5	24	11	11	0.0	15.9	1.4

Timber Sale Log Sort x Diameter Bin Summary

Sp	Bin	Status	Sort	Dia	Len	BF Net	Defect %	Tons	MBF Net
BC	5 - 7	LIVE	Domestic	6.3	30	17	0.0	14.8	2.2
BC	8 - 11	LIVE	Domestic	9.8	32	78	2.9	67.4	10.1
BC	16 - 19	LIVE	Domestic	17.5	40	113	5.0	82.7	14.6
DF	5 - 7	LIVE	Pulp	5.8	25	68	0.0	74.0	8.7
DF	5 - 7	LIVE	Domestic	6.7	31	4,164	1.2	4,715.7	538.5
DF	8 - 11	LIVE	Pulp	8.4	40	69	0.0	81.1	8.9
DF	8 - 11	LIVE	Pole	9.9	40	172	0.0	161.0	22.2
DF	8 - 11	LIVE	Domestic	10.1	37	9,607	1.3	9,533.1	1,242.2
DF	12 - 15	LIVE	Cull	12.7	8	0	100.0	0.0	0.0
DF	12 - 15	LIVE	Domestic	13.5	39	8,012	1.8	7,403.7	1,035.9
DF	12 - 15	LIVE	Pole	14.5	40	380	0.0	338.5	49.1
DF	16 - 19	LIVE	Domestic	17.3	38	4,567	1.9	3,642.7	590.5
DF	20+	LIVE	Domestic	24.3	40	744	2.4	504.0	96.2
DF	20+	LIVE	HQ-B	28.1	40	208	0.0	135.1	26.9
RA	5+	LIVE	Domestic	7.6	24	585	0.2	591.1	75.7
RC	5+	LIVE	Domestic	9.6	27	112	3.7	114.3	14.5
WH	5 - 7	LIVE	Domestic	6.5	27	677	0.0	890.5	87.5
WH	5 - 7	LIVE	Pulp	7.5	24	11	0.0	15.9	1.4

Sp	Bin	Status	Sort	Dia	Len	BF Net	Defect %	Tons	MBF Net
WH	8 - 11	LIVE	Domestic	10.0	36	1,882	2.4	2,303.0	243.4
WH	12 - 15	LIVE	Domestic	13.6	38	2,088	0.4	2,167.8	270.0
WH	12 - 15	LIVE	Cull	15.3	10	0	100.0	0.0	0.0
WH	16 - 19	LIVE	Domestic	17.3	38	875	1.0	801.9	113.1
WH	20+	LIVE	Domestic	23.4	40	850	1.3	643.7	109.9

DRAFT

Cruise Unit Report BEIGNET U1

Unit Sale Notice Volume (MBF): BEIGNET U1

Sp	DBH	Rings/In	Age	MBF Volume by Grade			
				All	2 Saw	3 Saw	4 Saw
DF	15.6	8.0		1,016	246	701	69
WH	15.4			51	12	34	5
RA	10.8			46		9	37
RC	13.3			7		5	2
ALL	14.9	8.0		1,119	258	749	112

Unit Cruise Design: BEIGNET U1

Design	Cruise Acres	FMA Acres	N Plots	N Cruise Plots	N Void Plots
B1C: VR, 1 BAF (54.44) Measure/Count Plots, Sighting Ht = 4.5 ft	27.8	31.9	20	10	0

Unit Cruise Summary: BEIGNET U1

Sp	Cruised Trees	All Trees	Trees/Plot	Ring-Count Trees
DF	44	96	4.8	1
WH	4	7	0.4	0
RA	4	6	0.3	0
RC	1	1	0.1	0
ALL	53	110	5.5	1

Unit Cruise Statistics: BEIGNET U1

Sp	BA (sq ft/acre)	BA CV (%)	BA SE (%)	V-BAR (bf/sq ft)	V-BAR CV (%)	V-BAR SE (%)	Net Vol (bf/acre)	Vol CV (%)	Vol SE (%)
DF	261.3	49.9	11.2	139.9	18.9	2.9	36,563	53.4	11.5
WH	19.1	212.9	47.6	96.0	21.7	10.8	1,829	214.0	48.8
RA	16.3	244.2	54.6	100.4	12.6	6.3	1,639	244.6	55.0
RC	2.7	447.2	100.0	87.1	0.0	0.0	237	447.2	100.0
ALL	299.4	40.7	9.1	134.5	22.1	3.0	40,268	46.3	9.6

Unit Summary: BEIGNET U1

Sp	Status	Rx	N	D	DBH	BL	THT	BF Gross	BF Net	Defect %	TPA	BA	RD	MBF Net
DF	LIVE	CUT	44	ALL	15.6	73	102	36,992	36,563	1.2	196.9	261.3	66.2	1,016.5
RA	LIVE	CUT	4	ALL	10.8	48	68	1,639	1,639	0.0	25.7	16.3	5.0	45.6
RC	LIVE	CUT	1	ALL	13.3	51	68	237	237	0.0	2.8	2.7	0.7	6.6
WH	LIVE	CUT	4	ALL	15.4	58	79	1,846	1,829	0.9	14.7	19.1	4.9	50.8
ALL	LIVE	CUT	53	ALL	15.1	69	96	40,715	40,268	1.1	240.1	299.4	76.7	1,119.5
ALL	ALL	ALL	53	ALL	15.1	69	96	40,715	40,268	1.1	240.1	299.4	76.7	1,119.5

DRAFT

Cruise Unit Report BEIGNET U2

Unit Sale Notice Volume (MBF): BEIGNET U2

Sp	DBH	Rings/In	Age	MBF Volume by Grade				
				All	2 Saw	3 Saw	4 Saw	Utility
DF	17.2			812	351	419	38	4
WH	14.2			30		23	7	
ALL	16.9			843	351	442	45	4

Unit Cruise Design: BEIGNET U2

Design	Cruise Acres	FMA Acres	N Plots	N Cruise Plots	N Void Plots
B2C: VR, 2 BAF (54.44, 40 for some species) Measure/Count Plots, Sighting Ht = 4.5 ft	25.5	29.1	18	10	0

Unit Cruise Summary: BEIGNET U2

Sp	Cruised Trees	All Trees	Trees/Plot	Ring-Count Trees
DF	41	77	4.3	0
WH	3	4	0.2	0
ALL	44	81	4.5	0

Unit Cruise Statistics: BEIGNET U2

Sp	BA (sq ft/acre)	BA CV (%)	BA SE (%)	V-BAR (bf/sq ft)	V-BAR CV (%)	V-BAR SE (%)	Net Vol (bf/acre)	Vol CV (%)	Vol SE (%)
DF	232.9	29.8	7.0	136.8	20.1	3.1	31,863	36.0	7.7
WH	12.1	246.7	58.2	98.6	12.7	7.4	1,192	247.1	58.6
ALL	245.0	30.7	7.2	134.9	21.1	3.2	33,055	37.3	7.9

Unit Summary: BEIGNET U2

Sp	Status	Rx	N	D	DBH	BL	THT	BF Gross	BF Net	Defect %	TPA	BA	RD	MBF Net
DF	LIVE	CUT	41	ALL	17.2	77	98	32,530	31,863	2.1	144.3	232.9	56.2	812.5
WH	LIVE	CUT	3	ALL	14.2	59	73	1,390	1,192	14.2	11.0	12.1	3.2	30.4
ALL	LIVE	CUT	44	ALL	17.0	76	96	33,919	33,055	2.5	155.3	245.0	59.4	842.9
ALL	ALL	ALL	44	ALL	17.0	76	96	33,919	33,055	2.5	155.3	245.0	59.4	842.9

Cruise Unit Report BEIGNET U3

Unit Sale Notice Volume (MBF): BEIGNET U3

Sp	DBH	Rings/In	Age	MBF Volume by Grade				
				All	2 Saw	3 Saw	4 Saw	Utility
WH	22.6			266	214	49	2	1
DF	39.1			113	113			
RC	31.2			7		7	0	
RA	17.4			4	3		1	
ALL	25.4			391	330	56	3	1

Unit Cruise Design: BEIGNET U3

Design	Cruise Acres	FMA Acres	N Plots	N Cruise Plots	N Void Plots
B2C: VR, 2 BAF (54.44, 40 for some species) Measure/Count Plots, Sighting Ht = 4.5 ft	8.5	9.2	9	6	0

Unit Cruise Summary: BEIGNET U3

Sp	Cruised Trees	All Trees	Trees/Plot	Ring-Count Trees
WH	14	26	2.9	0
DF	7	7	0.8	0
RC	2	2	0.2	0
RA	1	1	0.1	0
ALL	24	36	4.0	0

Unit Cruise Statistics: BEIGNET U3

Sp	BA (sq ft/acre)	BA CV (%)	BA SE (%)	V-BAR (bf/sq ft)	V-BAR CV (%)	V-BAR SE (%)	Net Vol (bf/acre)	Vol CV (%)	Vol SE (%)
WH	157.3	61.1	20.4	199.2	32.8	8.8	31,331	69.3	22.2
DF	42.3	124.9	41.6	314.4	8.6	3.3	13,311	125.2	41.8
RC	8.9	198.4	66.1	92.1	75.8	53.6	819	212.4	85.1
RA	4.4	300.0	100.0	113.2	0.0	0.0	503	300.0	100.0
ALL	212.9	33.0	11.0	215.8	40.7	8.3	45,964	52.4	13.8

Unit Summary: BEIGNET U3

Sp	Status	Rx	N	D	DBH	BL	THT	BF Gross	BF Net	Defect %	TPA	BA	RD	MBF Net
DF	LIVE	CUT	7	ALL	39.1	134	173	13,311	13,311	0.0	5.1	42.3	6.8	113.1
RA	LIVE	CUT	1	ALL	17.4	65	80	517	503	2.6	2.7	4.4	1.1	4.3
RC	LIVE	CUT	2	ALL	31.2	69	81	884	819	7.4	1.7	8.9	1.6	7.0
WH	LIVE	CUT	14	ALL	22.6	87	109	31,682	31,331	1.1	56.5	157.3	33.1	266.3
ALL	LIVE	CUT	24	ALL	24.3	89	112	46,394	45,964	0.9	66.0	212.9	42.5	390.7
ALL	ALL	ALL	24	ALL	24.3	89	112	46,394	45,964	0.9	66.0	212.9	42.5	390.7

Cruise Unit Report BEIGNET U4

Unit Sale Notice Volume (MBF): BEIGNET U4

Sp	DBH	Rings/In	Age	MBF Volume by Grade				
				All	2 Saw	3 Saw	4 Saw	Utility
DF	20.7			1,638	1,082	480	62	13
WH	17.6			476	266	177	33	
BC	24.5			20	20			
RA	16.0			12		12		
ALL	19.6			2,146	1,368	670	95	13

Unit Cruise Design: BEIGNET U4

Design	Cruise Acres	FMA Acres	N Plots	N Cruise Plots	N Void Plots
B2C: VR, 2 BAF (54.44, 40 for some species) Measure/Count Plots, Sighting Ht = 4.5 ft	62.3	72.0	31	17	0

Unit Cruise Summary: BEIGNET U4

Sp	Cruised Trees	All Trees	Trees/Plot	Ring-Count Trees
DF	46	86	2.8	0
WH	19	31	1.0	0
BC	1	1	0.0	0
RA	1	2	0.1	0
ALL	67	120	3.9	0

Unit Cruise Statistics: BEIGNET U4

Sp	BA (sq ft/acre)	BA CV (%)	BA SE (%)	V-BAR (bf/sq ft)	V-BAR CV (%)	V-BAR SE (%)	Net Vol (bf/acre)	Vol CV (%)	Vol SE (%)
DF	151.0	66.3	11.9	174.1	19.3	2.9	26,288	69.0	12.2
WH	54.4	171.3	30.8	140.3	23.5	5.4	7,638	172.9	31.2
BC	1.8	556.8	100.0	186.0	0.0	0.0	327	556.8	100.0
RA	2.6	556.8	100.0	75.9	0.0	0.0	196	556.8	100.0
ALL	209.8	46.3	8.3	164.2	22.9	2.8	34,449	51.7	8.8

Unit Summary: BEIGNET U4

Sp	Status	Rx	N	D	DBH	BL	THT	BF Gross	BF Net	Defect %	TPA	BA	RD	MBF Net
BC	LIVE	CUT	1	ALL	24.5	95	119	344	327	5.0	0.5	1.8	0.4	20.4
DF	LIVE	CUT	46	ALL	20.7	90	114	26,786	26,288	1.9	64.6	151.0	33.2	1,637.7
RA	LIVE	CUT	1	ALL	16.0	50	60	196	196	0.0	1.8	2.6	0.6	12.2
WH	LIVE	CUT	19	ALL	17.6	74	92	7,771	7,638	1.7	32.2	54.4	13.0	475.9
ALL	LIVE	CUT	67	ALL	19.7	84	106	35,096	34,449	1.8	99.1	209.8	47.2	2,146.2
ALL	ALL	ALL	67	ALL	19.7	84	106	35,096	34,449	1.8	99.1	209.8	47.2	2,146.2

DRAFT

Cruise Unit Report BEIGNET ROW1

Unit Sale Notice Volume (MBF): BEIGNET ROW1

Sp	DBH	Rings/In	Age	MBF Volume by Grade			
				All	2 Saw	3 Saw	4 Saw
DF	15.1			39	6	32	1
RA	12.7			14		4	10
BC	12.9			7	5		1
ALL	13.9			59	11	36	12

Unit Cruise Design: BEIGNET ROW1

Design	Cruise Acres	FMA Acres	N Plots	N Cruise Plots	N Void Plots
B1: VR, 1 BAF (40) Measure All, Sighting Ht = 4.5 ft	5.1	5.6	8	8	0

Unit Cruise Summary: BEIGNET ROW1

Sp	Cruised Trees	All Trees	Trees/Plot	Ring-Count Trees
DF	11	11	1.4	0
RA	7	7	0.9	0
BC	2	2	0.3	0
ALL	20	20	2.5	0

Unit Cruise Statistics: BEIGNET ROW1

Sp	BA (sq ft/acre)	BA CV (%)	BA SE (%)	V-BAR (bf/sq ft)	V-BAR CV (%)	V-BAR SE (%)	Net Vol (bf/acre)	Vol CV (%)	Vol SE (%)
DF	55.0	128.6	45.5	137.8	19.0	5.7	7,580	130.0	45.8
RA	35.0	113.3	40.0	76.2	22.9	8.7	2,667	115.6	41.0
BC	10.0	282.8	100.0	128.1	17.7	12.5	1,281	283.4	100.8
ALL	100.0	42.8	15.1	115.3	31.9	7.1	11,528	53.4	16.7

Unit Summary: BEIGNET ROW1

Sp	Status	Rx	N	D	DBH	BL	THT	BF Gross	BF Net	Defect %	TPA	BA	RD	MBF Net
BC	LIVE	CUT	2	ALL	12.9	75	93	1,281	1,281	0.0	11.0	10.0	2.8	6.5
DF	LIVE	CUT	11	ALL	15.1	69	94	7,597	7,580	0.2	44.2	55.0	14.2	38.7
RA	LIVE	CUT	7	ALL	12.7	57	70	2,667	2,667	0.0	39.8	35.0	9.8	13.6

Sp	Status	Rx	N	D	DBH	BL	THT	BF Gross	BF Net	Defect %	TPA	BA	RD	MBF Net
ALL	LIVE	CUT	20	ALL	13.9	65	84	11,545	11,528	0.1	95.0	100.0	26.8	58.8
ALL	ALL	ALL	20	ALL	13.9	65	84	11,545	11,528	0.1	95.0	100.0	26.8	58.8

DRAFT

Cruise Unit Report BEIGNET ROW2

Unit Sale Notice Volume (MBF): BEIGNET ROW2

Sp	DBH	Rings/In	Age	MBF Volume by Grade		
				All	2 Saw	3 Saw
WH	23.1			2	1	1
RC	36.2			1		1
DF	15.5			1		1
ALL	21.0			4	1	2

Unit Cruise Design: BEIGNET ROW2

Design	Cruise Acres	FMA Acres	N Plots	N Cruise Plots	N Void Plots
B2: VR, 2 BAF (54.44, 40 for some species) Measure All, Sighting Ht = 0 ft	0.1	0.1	1	1	0

Unit Cruise Summary: BEIGNET ROW2

Sp	Cruised Trees	All Trees	Trees/Plot	Ring-Count Trees
WH	2	2	2.0	0
RC	1	1	1.0	0
DF	1	1	1.0	0
ALL	4	4	4.0	0

Unit Cruise Statistics: BEIGNET ROW2

Sp	BA (sq ft/acre)	BA CV (%)	BA SE (%)	V-BAR (bf/sq ft)	V-BAR CV (%)	V-BAR SE (%)	Net Vol (bf/acre)	Vol CV (%)	Vol SE (%)
WH	108.9	0.0	0.0	181.0	15.3	10.8	19,711	15.3	10.8
RC	40.0	0.0	0.0	248.1	0.0	0.0	9,923	0.0	0.0
DF	54.4	0.0	0.0	154.2	0.0	0.0	8,393	0.0	0.0
ALL	203.3	0.0	0.0	187.0	23.0	11.5	38,027	23.0	11.5

Unit Summary: BEIGNET ROW2

Sp	Status	Rx	N	D	DBH	BL	THT	BF Gross	BF Net	Defect %	TPA	BA	RD	MBF Net
DF	LIVE	CUT	1	ALL	15.5	75	94	8,393	8,393	0.0	41.5	54.4	13.8	0.8
RC	LIVE	CUT	1	ALL	36.2	100	128	9,923	9,923	0.0	5.6	40.0	6.6	1.0
WH	LIVE	CUT	2	ALL	23.1	94	118	20,582	19,711	4.2	37.4	108.9	22.7	2.0

Sp	Status	Rx	N	D	DBH	BL	THT	BF Gross	BF Net	Defect %	TPA	BA	RD	MBF Net
ALL	LIVE	CUT	4	ALL	21.0	85	107	38,898	38,027	2.2	84.5	203.3	43.1	3.8
ALL	ALL	ALL	4	ALL	21.0	85	107	38,898	38,027	2.2	84.5	203.3	43.1	3.8

DRAFT

Beignet Cruise Map

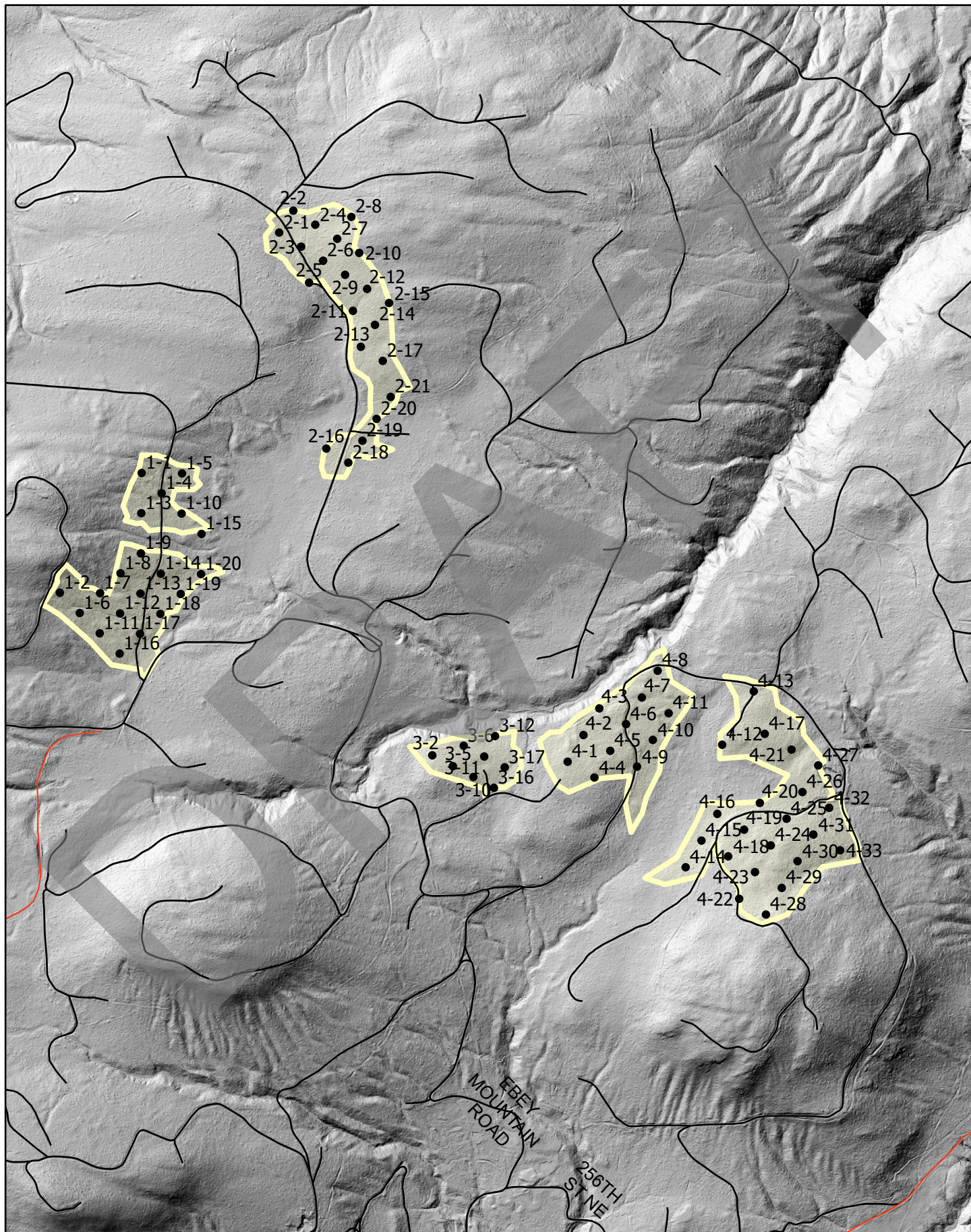



ROAD PLAN AND SPECIFICATIONS #30-105182 BEIGNET TIMBER SALE

SHEET INDEX	
PROJECT MAPS.....	1 - 2
ROAD CLAUSES	3 - 24
TYPICAL SECTION.....	25 - 27
MATERIAL LIST.....	28 - 29
FARMS.....	30 - 31
STANDARD DETAILS.....	32 - 34
PIT PLAN TEMPLATE.....	35

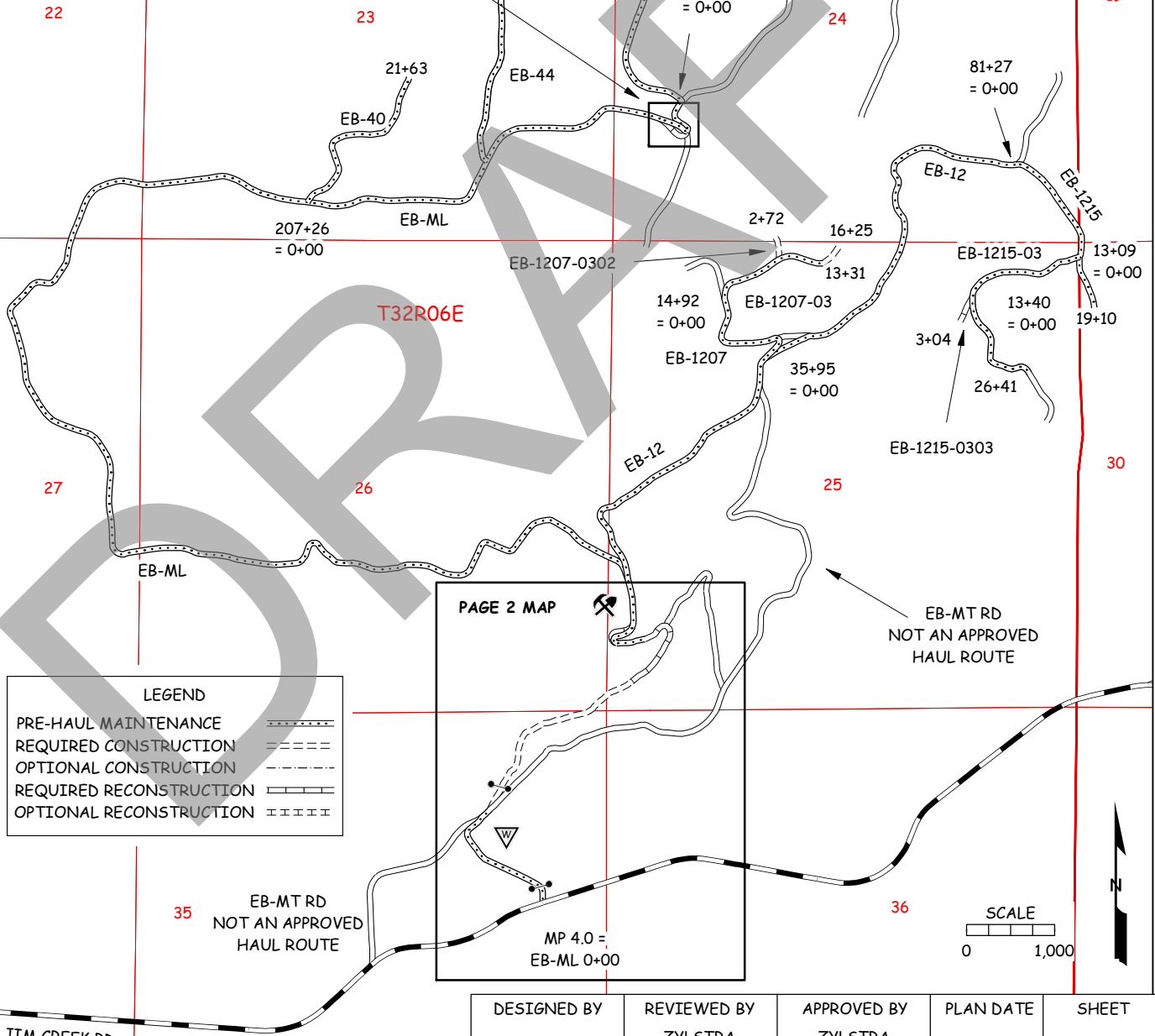
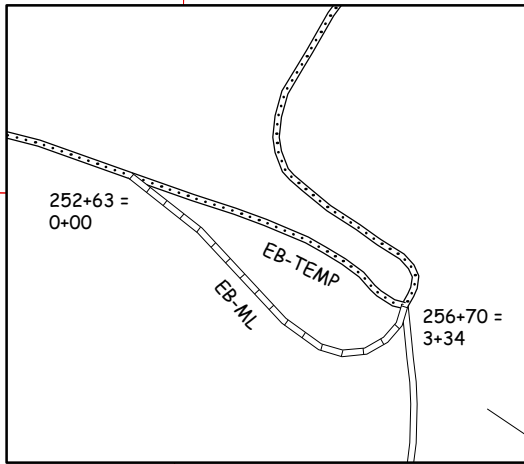

DESIGNED BY	REVIEWED BY	APPROVED BY	PLAN DATE	SHEET
J. WESTRA	ZYLSTRA 1/4/2024	ZYLSTRA 1/4/2024	12/14/2023	1 OF 35

JIM CREEK RD



ROAD PLAN AND SPECIFICATIONS #30-105182 BEIGNET TIMBER SALE

EBEY HILL PIT
57+20



58+46

EB-09

54+31

51+18

39+85

EB-ML

NOT AN APPROVED HAUL ROUTE

EB-MT ROAD

GATE INSTALL
17+00

16+27

12+57

EB-ML

JIM CREEK RD

MP 4.0 =
EB-ML 0+00

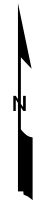
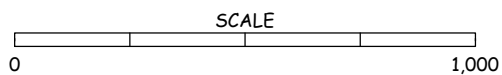

STATE OF WASHINGTON
DEPARTMENT OF NATURAL RESOURCES

BEIGNET TIMBER SALE ROAD PLAN
SNOHOMISH COUNTY
CASCADE DISTRICT
NORTHWEST REGION

AGREEMENT NO.: 30-105182

STAFF ENGINEER: J. WESTRA

DATE: DECEMBER 14, 2023

SECTION 0 – SCOPE OF PROJECT

0-1 ROAD PLAN SCOPE

Clauses in this road plan apply to all road related work, including landings and rock source development, unless otherwise noted.

0-2 REQUIRED ROADS

The specified work on the following roads is required.

<u>Road</u>	<u>Stations</u>	<u>Type</u>
EB-ML	0+00 to 16+27 51+18 to 306+73	PREHAUL MAINTENANCE
EB-ML	16+27 to 39+85	CONSTRUCTION
EB-ML	39+85 to 51+18 54+31 to 58+46 252+63 to 256+70	RECONSTRUCTION
EB-12	0+00 to 81+27	PREHAUL MAINTENANCE
EB-1207	0+00 to 14+29	PREHAUL MAINTENANCE
EB-1207-03	0+00 to 13+31	PREHAUL MAINTENANCE
EB-1207-03	13+31 to 16+25	CONSTRUCTION
EB-1207-0302	0+00 to 2+72	CONSTRUCTION
EB-1215	0+00 to 19+10	PREHAUL MAINTENANCE
EB-1215-03	0+00 to 26+41	PREHAUL MAINTENANCE
EB-1215-0303	0+00 to 3+04	RECONSTRUCTION
EB-40	0+00 to 21+63	PREHAUL MAINTENANCE
EB-44	0+00 to 24+80	PREHAUL MAINTENANCE
EB-TEMP	0+00 to 3+34	ABANDONMENT

0-4 CONSTRUCTION

Construction may include, but is not limited to clearing, grubbing, excavation and embankment to subgrade, drill and shoot, full-bench end-haul, landing and turnout construction, culvert installation and application of 3-inch-minus ballast.

0-5 RECONSTRUCTION

Reconstruction includes, but is not limited to clearing, grubbing, landing and turnout construction, culvert installation and application of 3-inch-minus ballast.

Additional reconstruction notes are listed below:

<u>Road</u>	<u>Stations</u>	<u>Requirements</u>
EB-ML	47+02 to 51+18	Construct 65' radius switchback, key lower leg fill onto existing abandoned road prism.
EB-ML	54+31 to 58+46	Move centerline into cutslope to widen switchback to a 65' radius. Endhaul waste.
EB-ML	252+63 to 256+70	Construct 65' radius curve and abandon existing road grade along stream.

0-6 PRE-HAUL MAINTENANCE

This project includes, but is not limited to the following pre-haul maintenance requirements:

<u>Road</u>	<u>Stations</u>	<u>Requirements</u>
EB-ML	0+00 to 16+27 51+18 to 306+73	BRUSHCUT
EB-12	0+00 to 81+27	
EB-1207	0+00 to 14+29	BRUSHCUT AND GRADE
EB-1207-03	0+00 to 13+31	
EB-1215	0+00 to 19+10	
EB-1215-03	0+00 to 26+41	
EB-40	0+00 to 21+63	
EB-44	0+00 to 24+80	

0-7 POST-HAUL MAINTENANCE

This project includes post-haul road maintenance listed in Clause 9-5 POST-HAUL MAINTENANCE.

0-11 ABANDONMENT BEFORE TIMBER REMOVAL

Purchaser shall abandon the following road at the start of the timber sale contract, before the removal of timber.

<u>Road</u>	<u>Stations</u>	<u>Requirements</u>
EB-TEMP	0+00 to 3+34	ABANDON CONCURRENT WITH 65' RADIUS CURVE CONSTRUCTION

0-12 DEVELOP ROCK SOURCE

Purchaser may develop an existing rock source. Rock source development will involve clearing, stripping, drilling, shooting and processing rock. Work for developing rock sources is listed in Section 6 ROCK AND SURFACING.

0-13 STRUCTURES

Purchaser shall provide and install a gate. Requirements for this structure is listed in Section 7 STRUCTURES.

SECTION 1 – GENERAL

1-1 ROAD PLAN CHANGES

If the Purchaser desires a change from this road plan including, but not limited to, relocation, extension, change in design, or adding roads; a revised road plan must be submitted in writing to the Contract Administrator for consideration. Before work begins, Purchaser shall obtain approval from the State for the submitted plan.

1-2 UNFORESEEN CONDITIONS

Quantities established in this road plan are minimum acceptable values. Additional quantities required by the state due to unforeseen conditions, or Purchaser's choice of construction season or techniques will be at the Purchaser's expense. Unforeseen conditions include, but are not limited to, solid subsurface rock, subsurface springs, saturated ground, and unstable soils.

1-3 ROAD DIMENSIONS

Purchaser shall perform road work in accordance with the dimensions shown on the TYPICAL SECTION SHEET and the specifications within this road plan.

1-4 ROAD TOLERANCES

Purchaser shall perform road work within the tolerances listed below. The tolerance class for each road is listed on the TYPICAL SECTION SHEET.

<u>Tolerance Class</u>	<u>A</u>	<u>B</u>	<u>C</u>
Road and Subgrade Width (feet)	+1.5	+1.5	+2.0
Subgrade Elevation (feet +/-)	0.5	1.0	2.0
Centerline alignment (feet lt./rt.)	1.0	1.5	3.0

1-6 ORDER OF PRECEDENCE

Any conflict or inconsistency in the road plan will be resolved by giving the documents precedence in the following order:

1. Addenda.
2. Road Plan Clauses.
3. Typical Section Sheet.
4. Standard Lists.
5. Standard Details.

In case of any ambiguity or dispute over interpreting the road plan, the Contract Administrator's or designee's decision will be final.

1-8 REPAIR OR REPLACEMENT OF DAMAGED MATERIALS

Purchaser shall repair or replace all materials, roadway infrastructure, and road components damaged during road work or operation activities. The Contract Administrator will direct repairs and replacements. Repairs to structural materials must be made in accordance with the manufacturer's recommendation.

1-9 DAMAGED METALLIC COATING

Any cut ends, or damaged galvanized or aluminized coating on existing or new bridge components, culverts, downspouts, and flumes must be cleaned and treated with a minimum of two coats of zinc rich paint or cold galvanizing compound.

1-15 ROAD MARKING

Purchaser shall perform road work in accordance with the state's marked location. All road work is marked as follows:

- Orange flagging and/or stakes for road centerline

1-18 REFERENCE POINT DAMAGE

Purchaser shall reset reference points (RPs) that were moved or damaged at any time during construction to their original locations. Excavation and embankment may not proceed on road segments controlled by said RPs until Purchaser resets all moved or damaged RPs.

1-21 HAUL APPROVAL

Purchaser shall not use roads under this road plan for any hauling other than timber cut on the right-of-way, without written approval from the Contract Administrator.

1-22 WORK NOTIFICATIONS

Purchaser shall notify the Contract Administrator a minimum of 3 business days before work begins.

1-23 ROAD WORK PHASE APPROVAL

Purchaser shall obtain written approval from the Contract Administrator upon completion of each of the following phases of road work:

- Subgrade construction and compaction
- Drainage installation
- Rock application and compaction

1-25 ACTIVITY TIMING RESTRICTION

The specified activities are not allowed during the listed closure period unless authorized in writing by the Contract Administrator.

<u>Road</u>	<u>Activity</u>	<u>Closure Period</u>
ALL ROADS	ALL ACTIVITIES	November 1 to March 31

1-26 OPERATING DURING CLOSURE PERIOD

If permission is granted to operate during a closure period listed in Clause 1-25 ACTIVITY TIMING RESTRICTION, Purchaser shall provide a maintenance plan to include further protection of state resources. Purchaser shall obtain written approval from the Contract Administrator for the maintenance plan, and shall put preventative measures in place before operating during the closure period. Purchaser is required to maintain all haul roads at their own expense including those listed in Contract Clause C-060 DESIGNATED ROAD MAINTAINER. If other operators are using, or desire to use these designated maintainer roads, a joint operating plan must be developed. All parties shall follow this plan.

Purchaser’s maintenance plan must include a total volume of rock that will be provided at the Purchaser’s expense in addition to what is specified in this road plan. This rock shall be available before permission is granted to operate during the closure period and will be used as necessary along the haul route. The Contract Administrator may direct the Purchaser where to apply this maintenance rock.

Rock from stockpiles may not be used for out of season maintenance.

1-29 SEDIMENT RESTRICTION

Purchaser shall not allow silt-bearing runoff to enter any streams.

1-30 CLOSURE TO PREVENT DAMAGE

In accordance with Contract Clause G-220 STATE SUSPENDS OPERATION, the Contract Administrator will suspend road work or hauling right-of-way timber, forest products, or rock under the following conditions:

- Wheel track rutting exceeds 4 inches on crushed rock roads.
- Surface or base stability problems persist.
- Weather is such that satisfactory results cannot be obtained in an area of operations.
- When, in the opinion of the Contract Administrator excessive road damage or rutting may occur.

Operations must stop unless authority to continue working or hauling is granted in writing by the Contract Administrator. In the event that surface or base stability problems persist, Purchaser shall cease operations, or perform corrective maintenance or repairs, subject to specifications within this road plan.

1-33 SNOW PLOWING RESTRICTION

Snowplowing will be allowed after the execution of a SNOW PLOWING AGREEMENT, which is available from the Contract Administrator upon request. If damage occurs while plowing, further permission to plow may be revoked by the Contract Administrator.

1-40 ROAD APPROACHES TO COUNTY ROADS AND STATE HIGHWAYS

Purchaser shall immediately remove any mud, dirt, rock, or other material tracked or spilled on to county roads and state highways.

If additional damage to the surface, signs, guardrails, etc. occurs then the damage will be repaired, at the Purchaser's expense, as directed by the Contract Administrator when authorized by the county or WSDOT.

SECTION 2 – MAINTENANCE

2-1 GENERAL ROAD MAINTENANCE

Purchaser shall maintain all roads used under this contract in accordance with the FOREST ACCESS ROAD MAINTENANCE SPECIFICATIONS for the entire term of this contract. Maintenance is required even during periods of inactivity.

2-2 ROAD MAINTENANCE – PURCHASER MAINTENANCE

Purchaser shall perform maintenance on roads listed in Contract Clause C-050 PURCHASER ROAD MAINTENANCE AND REPAIR in accordance with FOREST ACCESS ROAD MAINTENANCE SPECIFICATIONS.

2-4 PASSAGE OF LIGHT VEHICLES

Purchaser shall maintain all roads in a condition that will allow the passage of light administrative vehicles.

2-5 MAINTENANCE GRADING – EXISTING ROAD

On prehaul maintenance roads Purchaser shall use a grader to shape the existing surface before timber haul.

SECTION 3 – CLEARING, GRUBBING, AND DISPOSAL

3-1 BRUSHING

On all haul roads, Purchaser shall cut vegetative material up to 6 inches in diameter, including limbs, as shown on the BRUSHING DETAIL. Brushing must be achieved by mechanical cutting of brush, trees, and branches. Root systems and stumps of cut vegetation may not be disturbed unless directed by the Contract Administrator. Purchaser shall remove brushing debris from the road surface, ditchlines, and culvert inlets and outlets.

3-5 CLEARING

Purchaser shall fall all vegetative material larger than 2 inches DBH or over 5 feet high between the marked right-of-way boundaries and within waste and debris areas, or if not marked in the field, between the clearing limits specified on the TYPICAL SECTION SHEET. Clearing must be completed before starting excavation and embankment.

3-8 PROHIBITED DECKING AREAS

Purchaser shall not deck right-of-way timber in the following areas:

- Within the grubbing limits.
- Within 50 feet of any stream.
- In locations that interfere with the construction of the road prism.
- In locations that impede drainage.
- On slopes greater than 50%.
- Against standing trees.
-

3-10 GRUBBING

Purchaser shall remove all stumps between the grubbing limits specified on the TYPICAL SECTION SHEET. Purchaser shall also remove stumps with undercut roots outside the grubbing limits. Grubbing must be completed before starting excavation and embankment.

3-20 ORGANIC DEBRIS DEFINITION

Organic debris is defined as all vegetative material not eligible for removal by Contract Clause G-010 PRODUCTS SOLD AND SALE AREA or G-011 RIGHT TO REMOVE FOREST PRODUCTS AND CONTRACT AREA, that is larger than one cubic foot in volume within the clearing limits as shown on the TYPICAL SECTION SHEET and BRUSHING DETAIL.

3-21 DISPOSAL COMPLETION

Purchaser shall remove organic debris from the road surface, ditchlines, and culvert inlets and outlets. Purchaser shall complete all disposal of organic debris before the application of rock.

3-22 DESIGNATED WASTE AREA FOR ORGANIC DEBRIS

Waste areas for organic debris are located at areas approved in writing by the Contract Administrator.

3-23 PROHIBITED DISPOSAL AREAS

Purchaser shall not place organic debris in the following areas:

- Within 50 feet of a cross drain culvert.
- Within 100 feet of a live stream, or wetland
- On road subgrades, or excavation and embankment slopes.
- On slopes greater than 50%.
- Within the operational area for cable landings where debris may shift or roll.
- On locations where brush can fall into the ditch or onto the road surface.
- Against standing timber.

3-24 BURYING ORGANIC DEBRIS RESTRICTED

Purchaser shall not bury organic debris unless otherwise stated in this plan.

3-25 SCATTERING ORGANIC DEBRIS

Purchaser shall scatter organic debris outside of the clearing limits in natural openings unless otherwise detailed in this road plan.

3-32 END HAULING ORGANIC DEBRIS

On slopes greater than 45%, Purchaser shall end haul or push organic debris to the designated waste areas specified in Clause 3-22 DESIGNATED WASTE AREA FOR ORGANIC DEBRIS.

SECTION 4 – EXCAVATION

4-2 PIONEERING

Pioneering may not extend past construction that will be completed during the current construction season. Pioneering may not extend more than 500 feet beyond completed construction unless approved in writing by the Contract Administrator. In addition, the following actions must be taken as pioneering progresses:

- Drainage must be provided on all uncompleted construction.
- Road pioneering operations may not undercut the final cut slope or restrict drainage.
- Culverts at live stream crossings must be installed during pioneering operations prior to embankment.

4-3 ROAD GRADE AND ALIGNMENT STANDARDS

Purchaser shall follow these standards for road grade and alignment:

- Grade and alignment must have smooth continuity, without abrupt changes in direction.
- Maximum grades may not exceed 18 percent favorable and 15 percent adverse.
- Minimum curve radius is 60 feet at centerline.
- Maximum grade change for sag vertical curves is 5% in 100 feet.
- Maximum grade change for crest vertical curves is 4% in 100 feet.

4-4 SWITCHBACK STANDARDS

A switchback is defined as a curved segment of road between a beginning and end of the same curve, where the change of traffic travel direction is greater than 90 degrees.

Purchaser shall follow these standards for switchbacks:

- Maximum adverse grades for switchbacks is 10%.
- Maximum favorable grades for switchbacks is 12%.
- Maximum transition grades entering and leaving switchbacks is a 5% grade change.
- Transition grades required to meet switchback grade limitations must be constructed on the tangents preceding and departing from the switchbacks.

4-5 CUT SLOPE RATIO

Purchaser shall construct excavation slopes no steeper than shown on the following table:

<u>Material Type</u>	<u>Excavation Slope Ratio</u>	<u>Excavation Slope Percent</u>
Common Earth (on side slopes up to 55%)	1:1	100
Common Earth (on side slopes 56-70%)	¾:1	150
Fractured or loose rock	½:1	200
Hardpan or solid rock	¼:1	400

4-6 EMBANKMENT SLOPE RATIO

Purchaser shall construct embankment slopes no steeper than shown on the following table:

<u>Material Type</u>	<u>Embankment Slope Ratio</u>	<u>Embankment Slope Percent</u>
Sandy Soils	2:1	50
Common Earth and Rounded Gravel	1½:1	67
Angular Rock	1¼:1	80

4-7 SHAPING CUT AND FILL SLOPE

Purchaser shall construct excavation and embankment slopes to a uniform line and left rough for easier revegetation.

4-8 CURVE WIDENING

The minimum widening placed on the inside of curves is:

- 6 feet for curves of 50 to 79 feet radius.
- 4 feet for curves of 80 to 100 feet radius.

4-9 EMBANKMENT WIDENING

The minimum embankment widening is:

- 2 feet for embankment heights at centerline of 2 to 6 feet.
- 4 feet for embankment heights at centerline of greater than 6 feet.

Purchaser shall apply embankment widening equally to both sides of the road to achieve the required width.

4-12 FULL BENCH CONSTRUCTION

On the following road and where side slopes exceed 45%, Purchaser shall use full bench construction for the entire subgrade width. Purchaser shall end haul waste material to the location specified in Clause 4-37 WASTE AREA LOCATION.

<u>Road</u>	<u>Full Bench Location</u>	<u>Comments</u>
EB-ML	30+40 to 36+19	Approx. 3,800 yards
EB-ML	54+31 to 58+46	Approx. 1,500 yards

4-21 TURNOUTS

Purchaser shall construct turnouts intervisible with a maximum distance of 1,000 feet between turnouts unless otherwise shown on drawings. Locations may be adjusted to fit the final subgrade alignment and sight distances. Locations are subject to written approval by the Contract Administrator. Minimum dimensions are shown on the TYPICAL SECTION SHEET.

4-22 TURNAROUNDS

Purchaser shall construct turnarounds in accordance with the TURNAROUND DETAIL on all roads. Turnarounds must be no larger than 30 feet long and 30 feet wide. Locations are subject to written approval by the Contract Administrator.

4-25 DITCH CONSTRUCTION AND RECONSTRUCTION

Purchaser shall construct or reconstruct ditches into the subgrade as specified on the TYPICAL SECTION SHEET. Ditches must be constructed concurrently with construction of the subgrade.

4-27 DITCH WORK – MATERIAL USE PROHIBITED

Purchaser shall not pull ditch material across the road or mix in with the road surface. Excavated material must be end hauled to the location specified in Clauses 4-36 through 4-38.

4-28 DITCH DRAINAGE

Ditches must drain to cross-drain culverts or ditchouts.

4-29 DITCHOUTS

Purchaser shall construct ditchouts as identified on the MATERIALS LIST and as needed and as directed by the Contract Administrator. Ditchouts must be constructed in a manner that diverts ditch water onto the forest floor and must have excavation backslopes no steeper than a 1:1 ratio.

4-35 WASTE MATERIAL DEFINITION

Waste material is defined as all dirt, rock, mud, or related material that is extraneous or unsuitable for construction material. Waste material, as used in Section 4 EXCAVATION, is not organic debris.

4-36 DISPOSAL OF WASTE MATERIAL

Purchaser may sidecast waste material on side slopes up to 55% if the waste material is compacted and free of organic debris. On side slopes greater than 55%, all waste material must be end hauled or pushed to the designated embankment sites identified by the Contract administrator.

4-37 WASTE AREA LOCATION

Purchaser shall deposit waste material in the listed designated areas. Additional waste areas may also be identified or approved by the Contract Administrator.

<u>Road</u>	<u>Waste Area Location</u>	<u>Comments</u>
EB-ML	12+57	Fill in old utility access road, spread grass seed on all exposed soils.

4-38 PROHIBITED WASTE DISPOSAL AREAS

Purchaser shall not deposit waste material in the following areas:

- Within 50 feet of a cross drain culvert.
- Within 100 feet of a live stream or wetland.
- In locations that interfere with the construction of the road prism.
- In locations that impede drainage.
- Against standing timber.
- Outside the clearing limits.

4-60 FILL COMPACTION

Purchaser shall compact all embankment and waste material by routing equipment over the entire width of each lift.

4-61 SUBGRADE COMPACTION

Purchaser shall compact constructed and reconstructed subgrades by routing equipment over the entire width.

SECTION 5 – DRAINAGE

5-5 CULVERTS

Purchaser shall install culverts as part of this contract. Culverts must be installed concurrently with subgrade work and must be installed before subgrade compaction and rock application. Culvert locations and the minimum requirements for culvert length and diameter are designated on MATERIALS LIST. Culvert, downspout, and flume lengths may be adjusted to fit as-built conditions and may not terminate directly on unprotected soil. Culverts must be new material and must meet the specifications in Clauses 10-15 through 10-24.

5-12 UNUSED MATERIALS STATE PROPERTY

On required roads, any materials listed on the MATERIALS LIST that are not installed will become the property of the state. Purchaser shall stockpile materials as directed by the Contract Administrator.

5-15 CULVERT INSTALLATION

Culvert installation must be in accordance with the CULVERT AND DRAINAGE SPECIFICATION DETAIL and the National Corrugated Metal Pipe Association's "Installation Manual for Corrugated Steel Drainage Structures" and the Corrugated Polyethylene Pipe Association's "Recommended Installation Practices for Corrugated Polyethylene Pipe and Fittings".

5-17 CROSS DRAIN SKEW AND SLOPE

Cross drains, on road grades in excess of 3%, must be skewed at least 30 degrees from perpendicular to the road centerline, except where the cross drain is at the low point in the road culverts will not be skewed. Cross drain culverts must be installed at a slope steeper than the incoming ditch grade, but not less than 3% or more than 10%.

5-18 CULVERT DEPTH OF COVER

Cross drain culverts must be installed with a depth of cover of not less than 1 foot of compacted subgrade over the top of the culvert at the shallowest point. Stream crossing culverts must be installed with a depth of cover recommended by the culvert manufacturer for the type and size of the pipe.

5-20 ENERGY DISSIPATERS

Purchaser shall install energy dissipaters in accordance with the CULVERT AND DRAINAGE SPECIFICATION DETAIL. Energy dissipater installation is subject to approval by the Contract Administrator.

The type of energy dissipater and the amount of material must be consistent with the specifications listed on the CULVERT AND DRAINAGE SPECIFICATION DETAIL.

5-25 CATCH BASINS

Purchaser shall construct catch basins in accordance with CULVERT AND DRAINAGE SPECIFICATION DETAIL. Minimum dimensions of catch basins are 2 feet wide and 4 feet long.

5-26 HEADWALLS FOR CROSS DRAIN CULVERTS

Purchaser shall construct headwalls in accordance with the CULVERT AND DRAINAGE SPECIFICATION DETAIL at all cross drain culverts. Rock used for headwalls must weigh at least 50 pounds. Rock must be placed on shoulders, slopes, and around culvert inlets and outlets. Rock may not restrict the flow of water into culvert inlets or catch basins. No placement by end dumping or dropping of rock is allowed.

5-27 ARMORING FOR STREAM CROSSING CULVERTS

At stream crossing culverts, Purchaser shall place riprap in conjunction with construction of the embankment. Rock must be placed on shoulders, slopes, and around culvert inlets and outlets as designated on the MATERIALS LIST or as directed by the Contract Administrator. Rock may not restrict the flow of water into culvert inlets or catch basins. Placement must be by zero-drop-height method only. No placement by end dumping or dropping of rock is allowed.

SECTION 6 – ROCK AND SURFACING

6-2 ROCK SOURCE ON STATE LAND

Rock used in accordance with the quantities on the TYPICAL SECTION and MATERIALS LIST may be obtained from the following sources on state land at no charge to the Purchaser. Purchaser shall obtain written approval from the Contract Administrator for the use of material from any other source. If other operators are using, or desire to use the rock sources, a joint operating plan must be developed. All parties shall follow this plan.

<u>Source</u>	<u>Location</u>	<u>Rock Type</u>
EBEY HILL PIT	57+20 of the EB-ML	3-INCH MINUS BALLAST, RIPRAP

6-5 ROCK FROM COMMERCIAL SOURCE

Rock used in accordance with the quantities on the TYPICAL SECTION and MATERIALS LIST may be obtained from any commercial source at the Purchaser's expense.

6-11 ROCK SOURCE DEVELOPMENT PLAN BY PURCHASER

Purchaser shall conduct rock source development and use at the following sources, in accordance with a written ROCK SOURCE DEVELOPMENT PLAN to be prepared by the Purchaser. The plan is subject to written approval by the Contract Administrator before any rock source operations. Upon completion of operations, the rock source must be left in the condition specified in the ROCK SOURCE DEVELOPMENT PLAN, and approved in writing by the Contract Administrator.

<u>Source</u>	<u>Rock Type</u>	<u>Comment:</u>
EBEY HILL PIT	3-INCH MINUS BALLAST, RIPRAP	Use the attached LiDAR based template.

Rock source development plans prepared by the Purchaser must show the following information:

- Rock source location.
- Rock source overview showing access roads, development areas, stockpile locations, waste areas, and floor drainage.
- Rock source profiles showing development areas, bench locations including widths, and wall faces including heights.
- Rock source reclamation plan describing how the area will be left in a condition that will ensure public safety and minimize environmental impacts.
-

6-12 ROCK SOURCE SPECIFICATIONS

Rock sources must be in accordance with the following specifications:

- Pit walls may not be undermined or over steepened. The maximum slope of the walls must be consistent with recognized engineering standards for the type of material being excavated in accordance with the following table:

Material	Maximum Slope Ratio (Horiz. :Vert.)	Maximum Slope Percent
Sand	2:1	50
Gravel	1.5:1	67
Common Earth	1:1	100
Fractured Rock	0.5:1	200
Solid Rock	0:1	vertical

- Pit walls must be maintained in a condition to minimize the possibility of the walls sliding or failing.
- The width of pit benches must be a minimum of 1.5 times the maximum length of the largest machine used.
- The surface of pit floors and benches must be uniform and free-draining at a minimum 2% outslope gradient.
- All operations must be carried out in compliance with all regulations of the Regulations and Standards Applicable to Metal and Nonmetal Mining and Milling Operations (30 CFR) U.S. Department of Labor, Mine Safety and Health Administration and Safety Standards for Construction Work (296-155 WAC), Washington Department of Labor and Industries.
- All vehicle access to the top of the pit faces must be blocked.

6-14 DRILL AND SHOOT

Rock drilling and shooting must meet the following specifications:

- Oversize material remaining in the rock source at the conclusion of the timber sale may not exceed 5% of the total volume mined in that source.
- Oversize material is defined as rock fragments too large to be converted by the Purchaser to a size that will meet specifications used for the roads in this sale.
- All operations must be carried out in compliance with the Regulations and Standards Applicable to Metal and Nonmetal Mining and Milling Operations (30 CFR) U.S. Department of Labor, Mine Safety and Health Administration and the Safety Standards for Construction Work (296-155 WAC), Washington Department of Labor and Industries.
- Purchaser shall block access roads before blasting operations.

6-23 ROCK GRADATION TYPES

Purchaser shall provide rock in accordance with the types and amounts listed in the TYPICAL SECTION and MATERIALS LIST. Rock must meet the following specifications for gradation and uniform quality when placed in hauling vehicles or during manufacture and placement into a stockpile. The exact point of evaluation

The portion of aggregate retained on the No. 4 sieve may not contain more than 0.2 percent organic debris and trash. All percentages are by weight.

6-34 3-INCH MINUS BALLAST ROCK

Ballast rock must be 100% equal to, or smaller than, 3 inches in at least one dimension.

Rock may contain no more than 5 percent organic debris, dirt, and trash.

6-42 SHOT ROCK FILL

No more than 10 percent of the rock by weight may exceed 12 inches in any dimension and no rock may be larger than 18 inches in any dimension. Shotrock may not contain more than 5 percent by weight of organic debris and trash.

6-50 LIGHT LOOSE RIP RAP

Light loose rip rap must consist of angular, hard, sound, and durable stone. It must be free from segregation, seams, cracks, and other defects tending to destroy its resistance to weather. Light loose rip rap must be free of rock fines, soil, organic debris or other extraneous material, and must meet the following requirements:

<u>Quantity</u>	<u>Approximate Size Range</u>
20% to 90%	500 lbs. to 1 ton (18" - 28")
15% to 80%	50 lbs. to 500 lbs. (8" - 18")
10% to 20%	3 inch to 50 lbs. (3" - 8")

6-55 ROCK APPLICATION MEASURED BY COMPACTED DEPTH

Measurement of specified rock depths, are defined as the compacted depths using the compaction methods required in this road plan. Estimated quantities specified in the TYPICAL SECTION are loose yards. Purchaser shall apply adequate amounts of rock to meet the specified rock depths. Specified rock depths are minimum requirements, and are not subject to reduction.

6-70 APPROVAL BEFORE ROCK APPLICATION

Purchaser shall obtain written approval from the Contract Administrator for culvert installation, ditch construction, ditch reconstruction, headwall construction, and headwall reconstruction before rock application.

6-71 ROCK APPLICATION

Purchaser shall apply rock in accordance with the specifications and quantities shown on the TYPICAL SECTION. Rock must be spread, shaped, and compacted full width concurrent with rock hauling operations. The Contract Administrator will direct locations for rock that is to be applied as spot patching. Road surfaces must be compacted in accordance with the TYPICAL SECTION by routing equipment over the entire width.

6-73 ROCK FOR WIDENED PORTIONS

Purchaser shall apply rock to turnarounds, turnouts, and areas with curve widening to the same depth and specifications as the traveled way.

6-81 CHEMICAL TREATMENT FOR DUST ABATEMENT

Purchaser shall treat the following roads with Lignin Sulfonate for dust abatement. No other chemical may be used for dust abatement. The Lignin Sulfonate may not be used for any other purposes.

<u>Road</u>	<u>Stations</u>
EB-ML	12+60 to 17+60

6-82 CHEMICAL RESTRICTION

Purchaser shall not allow chemicals used for dust abatement to enter any streams.

6-83 LIGNIN SULFONATE APPLICATION RATE

The “as supplied” liquid Lignin Sulfonate must be diluted with an adequate amount of water to obtain a 25% solids content for application. Purchaser shall apply Lignin Sulfonate to the surface at a rate not less than 0.5 gallons per square yard (approximately 77.8 gallons per station).

6-85 CHEMICAL DUST ABATEMENT EQUIPMENT

Application equipment used to spread dust abatement chemicals must be capable of uniform application. A tanker truck with a “slash pan” or “plate” is not acceptable. Field dilution must be accomplished within the application vehicle.

6-86 TIMING FOR CHEMICAL APPLICATION

Purchaser shall obtain prior written approval from the Contract Administrator for the timing of application for dust abatement chemicals. It is intended that dust abatement chemicals be applied during the summer season.

SECTION 7 – STRUCTURES

7-76 GATE INSTALLATION

Purchaser shall install the listed gate. Gate installations must be completed within 30 days of commencement of road building operations.

<u>Road</u>	<u>Station</u>	<u>Type</u>	<u>Provided by</u>
EB-ML	17+00	Tubular with LOCK BOX	Purchaser

Tubular gate installation must be in accordance with the STEEL GATE DETAIL.

The gate and lock box must be installed plumb and aligned to ensure all mating components match with precision. Each post must be filled with concrete and set in a minimum of 2 cubic yards of poured-in-place concrete.

If Purchaser wishes to install an alternate design, detailed plans for the construction of the gate must be submitted to the Contract Administrator. Purchaser shall obtain written approval for the plans from the Contract Administrator or their designee, before gate installation begins.

Purchaser shall provide and place 10 cubic yards of stumps to prevent vehicles driving around the gate.

7-78 GATE SUPPLIED BY PURCHASER

Purchaser shall provide all gates specified for installation in Clause 7-76 GATE INSTALLATION. Purchaser shall obtain written approval for the gates from the Contract Administrator before installation.

SECTION 8 – EROSION CONTROL

8-2 PROTECTION FOR EXPOSED SOIL

Purchaser shall provide and evenly spread a 3-inch layer of straw to all exposed soils at culvert installations. Soils must be covered before the first anticipated storm event. Soils may not sit exposed during any rain event.

8-15 REVEGETATION

Purchaser shall spread seed and fertilizer on all exposed soils within the grubbing limits resulting from road work activities. Cover all exposed soils using manual dispersal of grass seed and fertilizer. Other methods of covering must be approved in writing by the Contract Administrator.

8-16 REVEGETATION SUPPLY

The Purchaser shall provide the seed and fertilizer.

8-17 REVEGETATION TIMING

Purchaser shall revegetate during the first available opportunity after road work is completed. Soils may not be allowed to sit exposed for longer than one month without receiving revegetation treatment unless otherwise approved in writing by the Contract Administrator.

8-18 PROTECTION FOR SEED

Purchaser shall provide a protective cover for seed if revegetation occurs between July 1 and March 31. The protective cover may consist of dispersed straw, jute matting, or clear plastic sheets. The protective cover requirement may be waived in writing by the Contract Administrator if Purchaser is able to demonstrate a revegetation plan that will result in the establishment of a uniform dense crop (at least 50% coverage) of 3-inch tall grass by October 31.

8-19 ASSURANCE FOR SEEDED AREA

Purchaser shall ensure the growth of a uniform and dense crop (at least 50% coverage) of 3-inch tall grass. Purchaser shall reapply the grass seed and fertilizer in areas that have failed to germinate or have been damaged through any cause. Restore eroded or disturbed areas, clean up and properly dispose of eroded materials, and reapply the seed and fertilizer at no addition cost to the state.

8-25 GRASS SEED

Purchaser shall evenly spread the seed mixture listed below on all exposed soil inside the grubbing limits at a rate of 50 pounds per acre of exposed soil. Grass seed must meet the following specifications:

1. Weed seed may not exceed 0.5% by weight.
2. All seed species must have a minimum 90% germination rate, unless otherwise specified.
3. Seed must be certified.
4. Seed must be furnished in standard containers showing the following information:
 - a. Common name of seed
 - b. Net weight
 - c. Percent of purity
 - d. Percentage of germination
 - e. Percentage of weed seed and inert material
5. Seed must conform to the following mixture.

<u>Kind and Variety of Seed in Mixture</u>	<u>% by Weight</u>
Creeping Red Fescue	50
Elf Perennial Rye Grass	25
Highland Colonial Bentgrass	15
White Clover	10
Inert and Other Crop	0.5

8-27 FERTILIZER

Purchaser shall evenly spread the fertilizer listed below on all exposed soil inside the grubbing limits at a rate of 200 pounds per acre of exposed soil. Fertilizer must meet the following specifications:

<u>Chemical Component</u>	<u>% by Weight</u>
Nitrogen	16
Phosphorous	16
Potassium	16
Sulphur	3
Inerts	49

SECTION 9 – POST-HAUL ROAD WORK

9-3 CULVERT MATERIAL REMOVED FROM STATE LAND

Culverts removed from roads become the property of the Purchaser and must be removed from state land.

9-5 POST-HAUL MAINTENANCE

Purchaser shall perform post-haul maintenance in accordance with the FOREST ACCESS ROAD MAINTENANCE SPECIFICATIONS and as specified below.

9-10 LANDING DRAINAGE

Purchaser shall provide for drainage of the landing surface.

9-11 LANDING EMBANKMENT

Purchaser shall slope landing embankments to the original construction specifications.

9-21 ROAD ABANDONMENT

Purchaser shall abandon the following roads before the termination of this contract.

<u>Road</u>	<u>Stations</u>
EB-TEMP	0+00 to 3+34

9-22 ABANDONMENT

- Remove all ditch relief culverts. The resulting slopes must be 1:1 or flatter. Place and compact the removed fill material in a location that will not erode into any Type 1 through 5 waters or wetlands.
- Remove all culverts in natural drainages. The resulting slopes must be 1.5:1 or flatter. Strive to match the existing native stream bank gradient. The natural streambed width must be re-established. Place and compact the removed fill material in a location that will not erode into any Type 1 through 5 waters or wetlands.
- Transport all removed culverts off site. All removed culverts are the property of the Purchaser.
- Construct non-drivable waterbars at natural drainage points and at a spacing that will produce a vertical drop of no more than 20 feet between waterbars and with a maximum horizontal spacing of 400 feet.
- Skew waterbars at least 30 degrees from perpendicular to the road centerline on roads in excess of 3 percent grade.
- Key waterbars into the cut-slope to intercept the ditch. Waterbars must be outsloped to provide positive drainage. Outlets must be on stable locations.
- Inslope or outslope the road as appropriate.
- Remove bridges and other structures.
- Pull back unstable fill that has potential of failing and entering any Type 1 through 5 waters or wetlands. Place and compact removed material in a stable location.

- Remove berms except as designed.
- Block the road by constructing an aggressive barrier of dense interlocked large woody debris (logs, stumps, root wads, etc.) so that four wheel highway vehicles cannot pass the point of abandonment. Typical barrier dimensions are 10 feet high by 20 feet deep, spanning the entire road prism from top of cutslope to toe of fillslope. Long term effectiveness is the primary objective. If necessary construct a vehicular turn-around near the point of abandonment.
- Apply grass seed to all exposed soils resulting from the abandonment work and in accordance with Section 8 EROSION CONTROL.

SECTION 10 MATERIALS

10-15 CORRUGATED STEEL CULVERT

Metallic coated steel culverts must meet AASHTO M-36 (ASTM A-760) specifications. Culverts must be galvanized (zinc coated meeting AASHTO M-218).

10-17 CORRUGATED PLASTIC CULVERT

Polyethylene culverts must meet AASHTO M-294 specifications, or ASTM F-2648 specifications for recycled polyethylene. Culverts must be Type S – double walled with a corrugated exterior and smooth interior.

10-21 METAL BAND

Metal coupling and end bands must meet the AASHTO specification designated for the culvert and must have matching corrugations. Culverts 24 inches and smaller must have bands with a minimum width of 12 inches. Culverts over 24 inches must have bands with a minimum width of 24 inches.

10-22 PLASTIC BAND

Plastic coupling and end bands must meet the AASHTO specification designated for the culvert. Only fittings supplied or recommended by the culvert manufacturer may be used.

10-24 GAUGE AND CORRUGATION

Metal culverts must conform to the following specifications for gage and corrugation as a function of diameter.

<u>Diameter</u>	<u>Gage</u>	<u>Corrugation</u>
18"	16 (0.064")	2 ² / ₃ " X 1 ¹ / ₂ "
24" to 48"	14 (0.079")	2 ² / ₃ " X 1 ¹ / ₂ "
54" to 96"	14 (0.079")	3" X 1"

ROAD #		EB-ML	EB-ML	EB-ML	EB-ML
REQUIRED / OPTIONAL		REQUIRED	REQUIRED	REQUIRED	REQUIRED
CONSTRUCT / RECONSTRUCT		PREHAUL	CONSTRUCT	RECONSTRUCT	PREHAUL
TOLERANCE CLASS (A/B/C)		C	C	C	C
STATION / MP TO		0+00	16+27	39+85	51+18
STATION / MP		16+27	39+85	51+18	54+31
ROAD WIDTH	R	12	12	12	12
CROWN (INCHES @ C/L)		3	3	3	3
DITCH WIDTH	W	3	3	3	3
DITCH DEPTH	D	1	1	1	1
TURNOUT LENGTH	L	--	50	50	--
TURNOUT WIDTH	T	--	10	10	--
TURNOUT TAPER	P	--	25	25	--
GRUBBING	G1	--	5	5	--
	G2	--	5	5	--
CLEARING	C1	--	10	10	--
	C2	--	10	10	--
ROCK FILLSLOPE	K:1	--	1 ½ : 1	1 ½ : 1	--
❖ BALLAST DEPTH	B1	--	18	18	--
CUBIC YARDS / STATION		--	114	114	--
➤ TOTAL CY BALLAST		--	2,690	1,290	--
❖ SURFACING DEPTH	B2	--	--	--	--
CUBIC YARDS / STATION		--	--	--	--
➤ TOTAL CY SURFACING		--	--	--	--
➤ TOTAL CUBIC YARDS		--	2,690	1,290	--
SUBGRADE WIDTH	S	--	16.5	16.5	--
BRUSHCUT (Y/N)		Y	N	N	Y
BLADE, SHAPE, & DITCH (Y/N)		N	N	N	N

TYPICAL SECTION

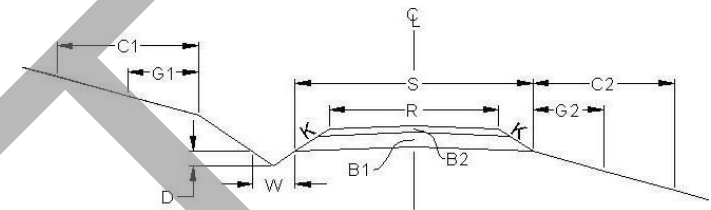

TURNOUT DETAIL (PLAN VIEW)

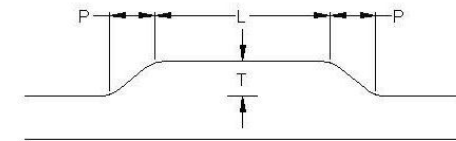

SYMBOL NOTES

- ❖ Specified Rock Depth is FINISHED COMPACTED DEPTH in inches.
- Specified Rock Quantity is LOOSE MEASURE (Truck Cubic Yards) needed to accomplish specified FINISHED COMPACTED DEPTH. Rock quantities include volume for turnouts, curve widening and landings.

Rock Totals Summary

Type	Quantity (Cubic Yards)
Ballast	5,725
Shotrock	210
Rip Rap	119

ROAD #		EB-ML	EB-ML	EB-ML	EB-ML	EB-12	EB-1207	EB-1207-03	EB-1207-03
REQUIRED / OPTIONAL		REQUIRED	REQUIRED	REQUIRED	REQUIRED	REQUIRED	REQUIRED	REQUIRED	REQUIRED
CONSTRUCT / RECONSTRUCT		RECONSTRUCT	PREHAUL	RECONSTRUCT	PREHAUL	PREHAUL	PREHAUL	PREHAUL	CONSTRUCT
TOLERANCE CLASS (A/B/C)		C	C	C	C	C	C	C	C
STATION / MP TO		54+31	58+46	252+63	256+70	0+00	0+00	0+00	13+31
STATION / MP		58+46	252+63	256+70	306+73	81+27	14+29	13+31	16+25
ROAD WIDTH	R	12	12	12	12	12	12	12	12
CROWN (INCHES @ C/L)		3	3	3	3	3	3	3	3
DITCH WIDTH	W	3	3	3	3	3	3	3	3
DITCH DEPTH	D	1	1	1	1	1	1	1	1
TURNOUT LENGTH	L	--	--	--	--	--	--	--	--
TURNOUT WIDTH	T	--	--	--	--	--	--	--	--
TURNOUT TAPER	P	--	--	--	--	--	--	--	--
GRUBBING	G1	5	--	5	--	--	--	--	5
	G2	5	--	5	--	--	--	--	5
CLEARING	C1	10	--	10	--	--	--	--	10
	C2	10	--	10	--	--	--	--	10
ROCK FILLSLOPE	K:1	1 ½ : 1	--	1 ½ : 1	--	--	--	--	1 ½ : 1
❖ BALLAST DEPTH	B1	18	--	18	--	--	--	--	18
CUBIC YARDS / STATION		114	--	114	--	--	--	--	114
➤ TOTAL CY BALLAST		475	--	465	--	--	--	--	335
❖ SURFACING DEPTH	B2	--	--	--	--	--	--	--	--
CUBIC YARDS / STATION		--	--	--	--	--	--	--	--
➤ TOTAL CY SURFACING		--	--	--	--	--	--	--	--
➤ TOTAL CUBIC YARDS		475	--	465	--	--	--	--	335
SUBGRADE WIDTH	S	16.5	--	16.5	--	--	--	--	16.5
BRUSHCUT (Y/N)		Y	Y	Y	Y	Y	Y	Y	N
BLADE, SHAPE, & DITCH (Y/N)		N	N	N	N	N	Y	Y	N

ROAD #		EB-1207-0302	EB-1215	EB-1215-03	EB-1215-0303	EB-40	EB-44
REQUIRED / OPTIONAL		REQUIRED	REQUIRED	REQUIRED	REQUIRED	REQUIRED	REQUIRED
CONSTRUCT / RECONSTRUCT		CONSTRUCT	PREHAUL	PREHAUL	RECONSTRUCT	PREHAUL	PREHAUL
TOLERANCE CLASS (A/B/C)		C	C	C	C	C	C
STATION / MP TO		0+00	0+00	0+00	0+00	0+00	0+00
STATION / MP		2+72	19+10	26+41	3+04	21+63	24+80
ROAD WIDTH	R	12	12	12	12	12	12
CROWN (INCHES @ C/L)		3	3	3	3	3	3
DITCH WIDTH	W	3	3	3	3	3	3
DITCH DEPTH	D	1	1	1	1	1	1
TURNOUT LENGTH	L	--	--	--	--	--	--
TURNOUT WIDTH	T	--	--	--	--	--	--
TURNOUT TAPER	P	--	--	--	--	--	--
GRUBBING	G1	5	--	--	5	--	--
	G2	5	--	--	5	--	--
CLEARING	C1	10	--	--	10	--	--
	C2	10	--	--	10	--	--
ROCK FILLSLOPE	K:1	1 ½ : 1	--	--	1 ½ : 1	--	--
❖ BALLAST DEPTH	B1	18	--	--	9	--	--
CUBIC YARDS / STATION		114	--	--	53	--	--
➤ TOTAL CY BALLAST		310	--	--	160	--	--
❖ SURFACING DEPTH	B2	--	--	--	--	--	--
CUBIC YARDS / STATION		--	--	--	--	--	--
➤ TOTAL CY SURFACING		--	--	--	--	--	--
➤ TOTAL CUBIC YARDS		310	--	--	160	--	--
SUBGRADE WIDTH	S	16.5	--	--	16.5	--	--
BRUSHCUT (Y/N)		N	Y	Y	N	Y	Y
BLADE, SHAPE, & DITCH (Y/N)		N	Y	Y	N	Y	Y

MATERIALS LIST

LOCATION		CULVERT			DWNSPT		RIPRAP			FILL TYPE	TOLERANCE	REMARKS		
ROAD #	STATION	DIAMETER	LENGTH	TYPE	LENGTH	TYPE	INLET	OUTLET	TYPE			Note: Galvanized metal culverts shall conform to the following specifications for gage and corrugation as a function of the diameter:		
												Diameter	Gage	Corrugation
		18"										18" 16 2 2/3" x 1/2"		
		24" – 48"										14 2 2/3" x 1/2"		
		54" – 96"										14 3" x 1"		
EB-ML	19+64	18	40	PD	--	--	2	3	L	NT	C			
EB-ML	21+30	30	40	PD	--	--	2	3	L	SR	C	TYPE 5 STREAM		
EB-ML	22+40	30	40	PD	--	--	2	3	L	SR	C	TYPE 5 STREAM		
EB-ML	23+45	18	30	PD	--	--	2	3	L	NT	C			
EB-ML	25+27	30	35	PD	--	--	2	3	L	SR	C	TYPE 5 STREAM		
EB-ML	26+49	36	35	GM	--	--	3	5	L	SR	C	TYPE 4 STREAM		
EB-ML	27+83	30	35	PD	--	--	2	3	L	SR	C	TYPE 5 STREAM		
EB-ML	28+47	36	35	GM	--	--	3	5	L	SR	C	TYPE 4 STREAM		
EB-ML	28+99	18	30	PD	--	--	2	3	L	NT	C			
EB-ML	29+99	18	30	PD	--	--	2	3	L	NT	C			
EB-ML	31+31	36	40	GM	--	--	3	5	L	SR	C	TYPE 4 STREAM		
EB-ML	31+72	18	30	PD	--	--	2	3	L	NT	C			
EB-ML	33+66	18	30	PD	--	--	2	3	L	NT	C			
EB-ML	34+62	18	30	PD	--	--	2	3	L	NT	C			
EB-ML	36+01	18	30	PD	--	--	2	3	L	NT	C			
EB-ML	36+99	18	30	PD	--	--	2	3	L	NT	C			
EB-ML	39+38	18	30	PD	--	--	2	3	L	NT	C			
EB-ML	42+84	18	30	PD	--	--	2	3	L	NT	C			
EB-ML	45+39	18	30	PD	--	--	2	3	L	NT	C			

GM – Galvanized Metal PS – Polyethylene Pipe Single Wall PD – Polyethylene Pipe Dual Wall AM – Aluminized Metal C – Concrete XX – PD or GM
 H – Heavy Loose Riprap L – Light Loose Riprap SR – Shot Rock NT – Native (Bank Run) QS – Quarry Spalls

FOREST ACCESS ROAD MAINTENANCE SPECIFICATIONS

Cuts and Fills

- Maintain slope lines to a stable gradient compatible with the construction materials. Remove slides from ditches and the roadway. Repair fill-failures, in accordance with Clause 4-6 EMBANKMENT SLOPE RATIO, with selected material or material approved by the Contract Administrator. Remove overhanging material from the top of cut slopes.
- Waste material from slides or other sources shall be placed and compacted in stable locations identified in the road plan or approved by the Contract Administrator, so that sediment will not deliver to any streams or wetlands.
- Slide material and debris shall not be mixed into the road surface materials, unless approved by the Contract Administrator.

Surface

- Grade and shape the road surface, turnouts, and shoulders to the original shape on the TYPICAL SECTION SHEET. Inslope or outslope as directed to provide a smooth, rut-free traveled surface and maintain surface water runoff in an even, unconcentrated manner.
- Blading shall not undercut the backslope or cut into geotextile fabric on the road.
- If required by the Contract Administrator, water shall be applied as necessary to control dust and retain fine surface rock.
- Surface material shall not be bladed off the roadway. Replace surface material when lost or worn away, or as directed by the Contract Administrator.
- Remove shoulder berms, created by grading, to facilitate drainage, except as marked or directed by the Contract Administrator.
- For roads with geotextile fabric: spread surface aggregate to fill in soft spots and wheel ruts (barrel spread) to prevent damage to the geotextile fabric.

Drainage

- Prevent silt bearing road surface and ditch runoff from delivering sediment to any streams or wetlands.
- Maintain rolling dips and drivable waterbars as needed to keep them functioning as intended.
- Maintain headwalls to the road shoulder level with material that will resist erosion.
- Maintain energy dissipaters at culvert outlets with non-erodible material or rock.
- Keep ditches, culverts, and other drainage structures clear of obstructions and functioning as intended.
- Inspect and clean culverts at least monthly, with additional inspections during storms and periods of high runoff. This shall be done even during periods of inactivity.

FOREST ACCESS ROAD MAINTENANCE SPECIFICATIONS

Preventative Maintenance

- Perform preventative maintenance work to safeguard against storm damage, such as blading to ensure correct runoff, ditch and culvert cleaning, and waterbar maintenance.

Termination of Use or End of Season

- At the conclusion of logging operations, ensure all conditions of these specifications have been met.

Debris

- Remove fallen timber, limbs, and stumps from the slopes, roadway, ditchlines, and culvert inlets.

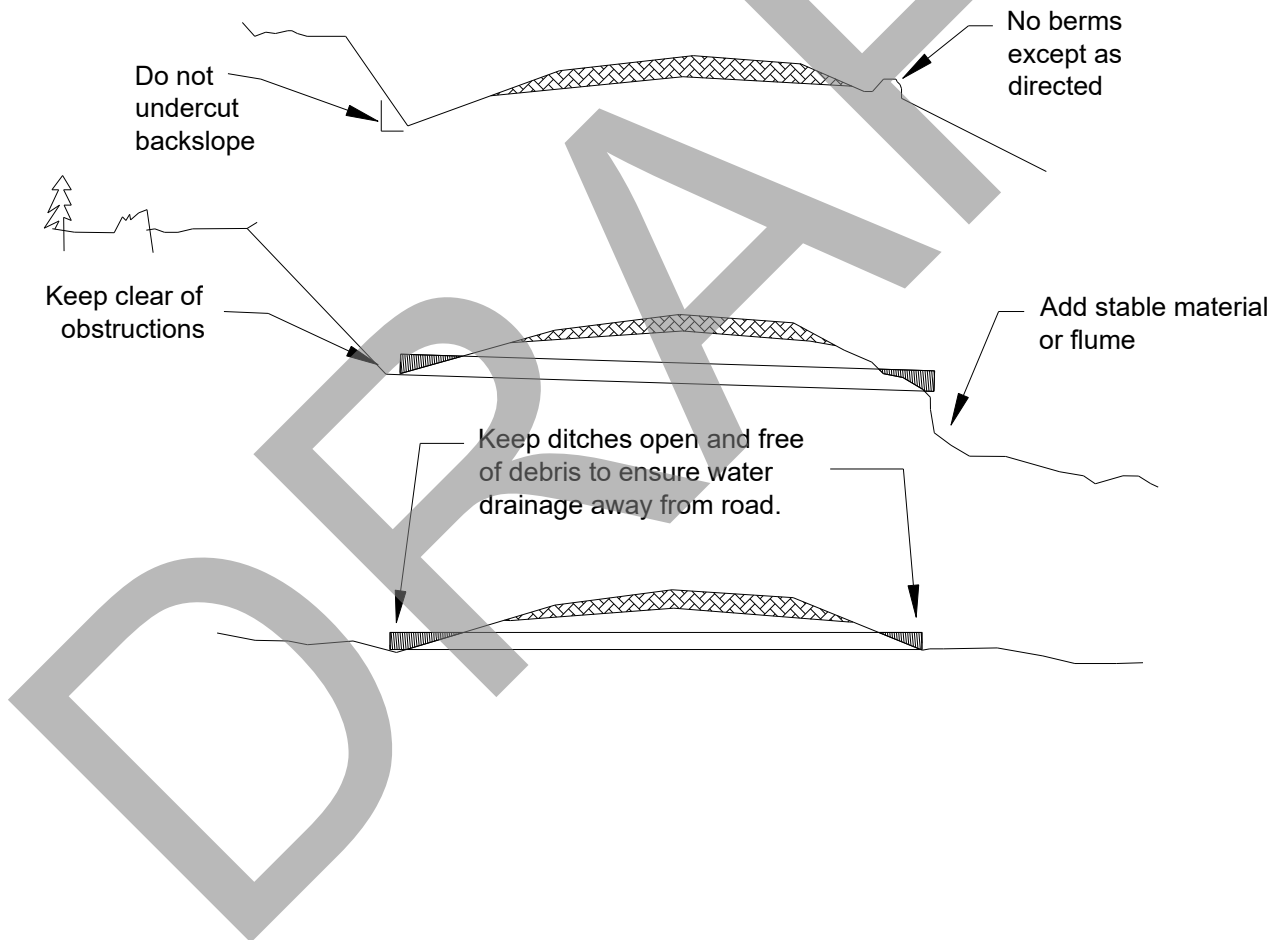

TURNAROUND DETAILS

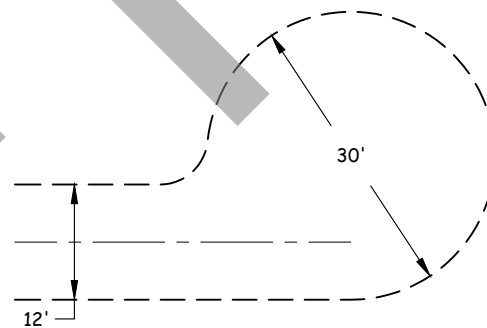
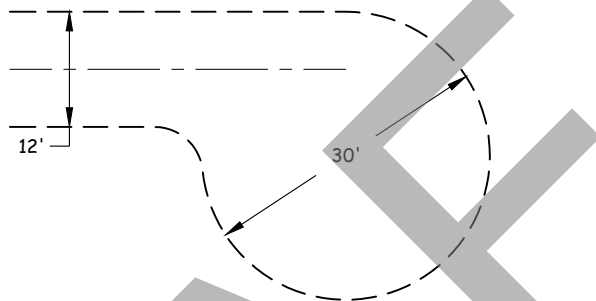
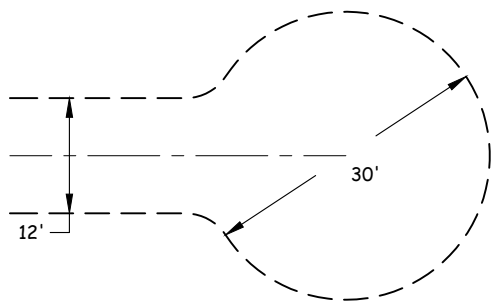

CUL-DE-SAC

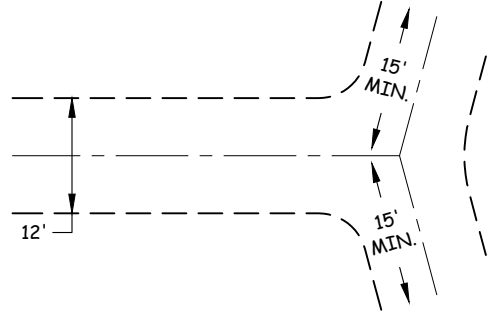
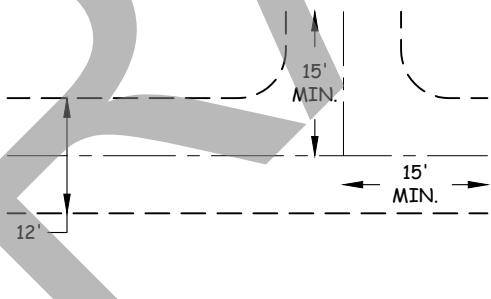
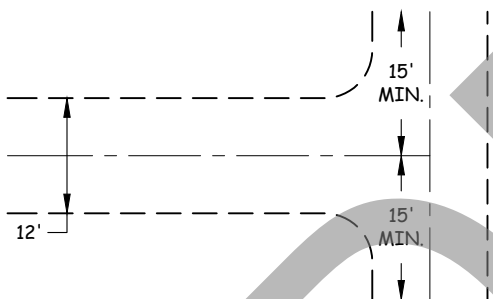

HAMMERHEAD

3-POINT SIDE

3-POINT WYE

TURNAROUND TYPE AND TURNAROUND LOCATION ARE SUBJECT TO THE APPROVAL OF THE CONTRACT ADMINISTRATOR.

ROCK SHALL BE APPLIED THROUGHOUT THE TURNAROUND TO THE SAME DEPTH AND SPECIFICATIONS AS LISTED IN THE TYPICAL SECTION.

CONTRACT # 30-105182	PROJECT BEIGNET	SHEET 32 OF 35
-------------------------	--------------------	-------------------

CULVERT AND DRAINAGE SPECIFICATIONS

CULVERT INSTALLATION (TYPICAL)

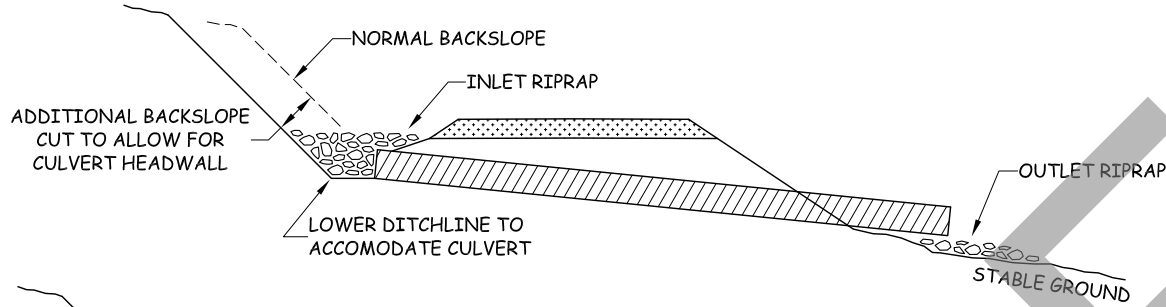

CULVERT HEADWALL - SECTION VIEW

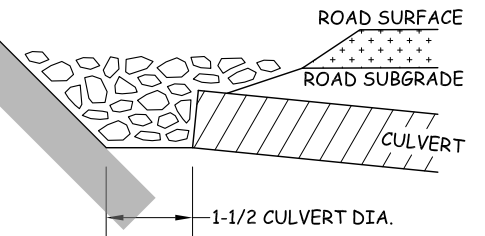

CULVERT INSTALLATION WITH DOWNSPOUT

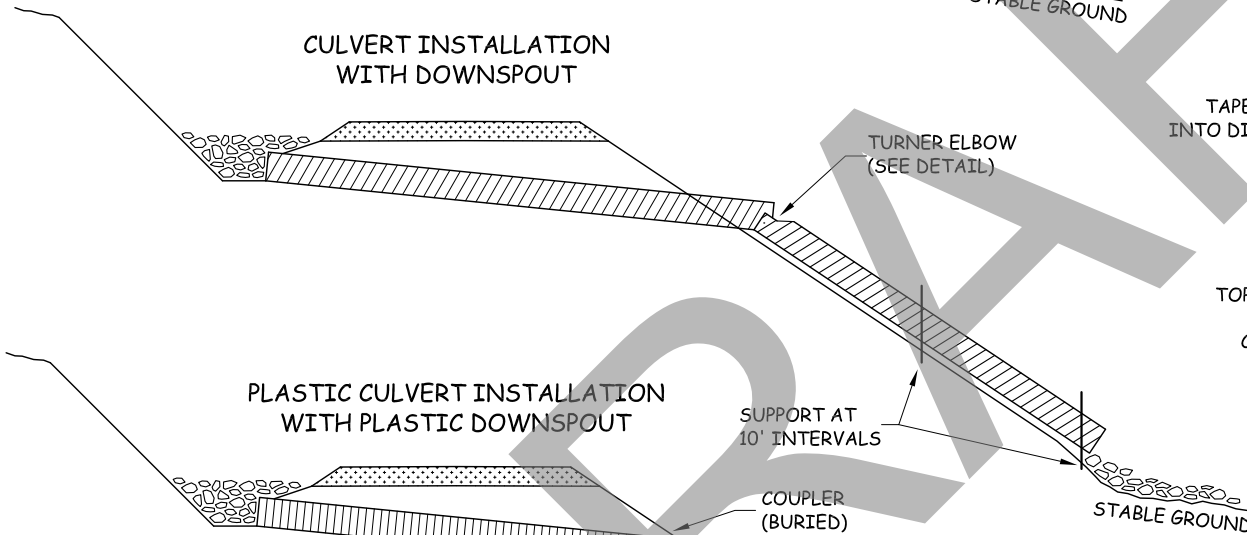

CULVERT HEADWALL - PLAN VIEW

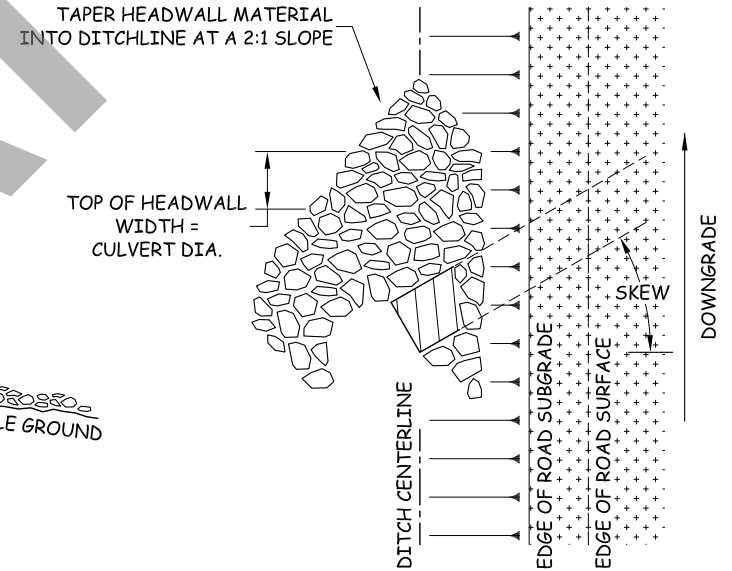

PLASTIC CULVERT INSTALLATION WITH PLASTIC DOWNSPOUT

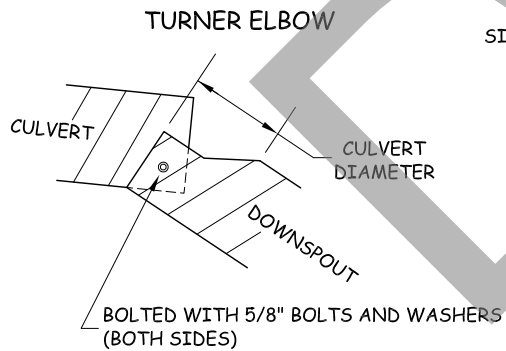
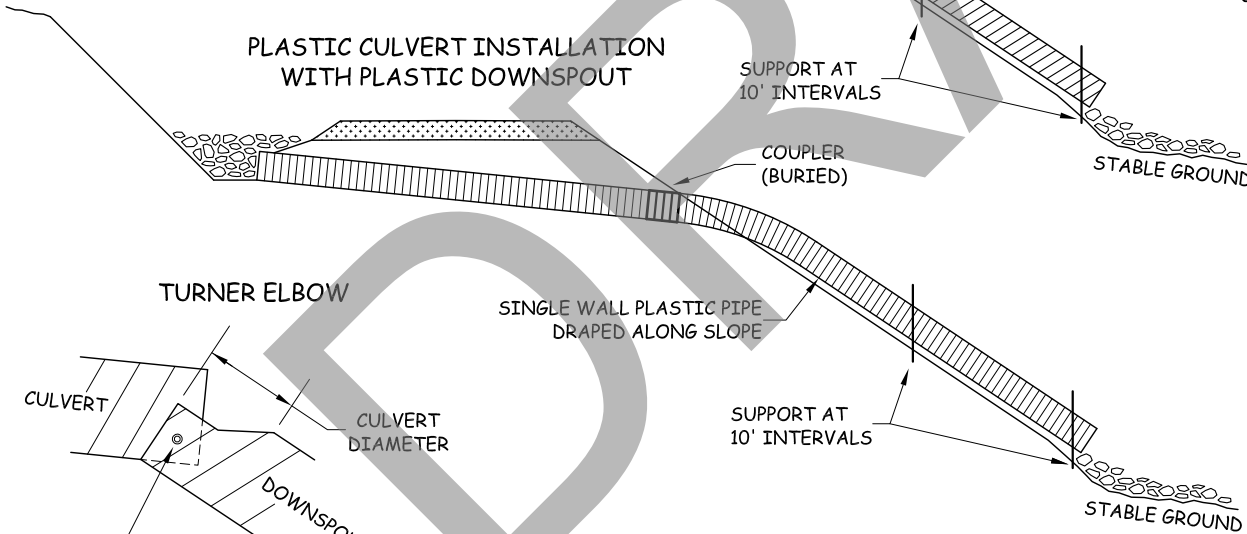

HEADWALL NOTE:
 HEADWALL TO BE CONSTRUCTED OF IMPERVIOUS MATERIAL THAT WILL RESIST EROSION AND ARMORED WITH RIPRAP QUANTITY SPECIFIED IN ROAD PLAN.

CONTRACT #	PROJECT	SHEET
30-105182	BEIGNET	33 OF 35

STEEL GATE INSTALLATION

EB-ML 17+00

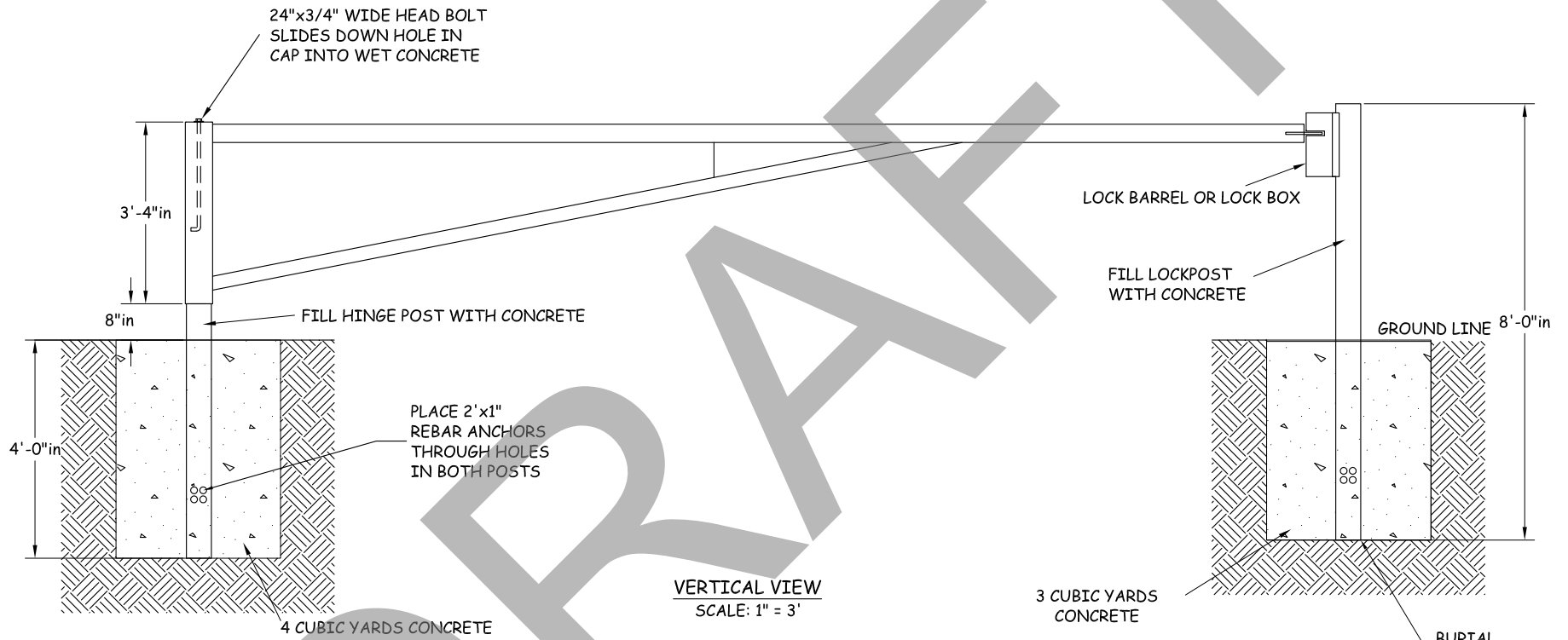

CONSTRUCTION NOTES

1. ALL WELDS ARE FILLET WELDS.
2. ACTUAL LOCATION SHALL BE DESIGNATED BY THE CONTRACT ADMINISTRATOR.
3. ALL CONCRETE SHALL MEET MINIMUM REQUIREMENTS FOR CLASS B CONCRETE.

CONTRACT #	PROJECT	SHEET
30-105182	BEIGNET	34 OF 35

PIT DEVELOPMENT PLAN TEMPLATE

EBEY HILL PIT -- 57+20 OF THE EB-ML



REQUIRED RECONSTRUCTION,
SEE CLAUSE 0-5

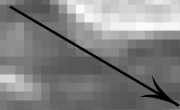

58+46

EB-ML

54+31

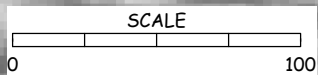

CONTRACT #
30-105182

PROJECT
BEIGNET

SHEET
35 OF 35

SUMMARY - Road Development Costs

REGION: NW

DISTRICT: Clear Lake

SALE/PROJECT NAME: Beignet

CONTRACT #: 30-105182

ROAD NUMBERS:	EB-ML, EB-1207-03, EB-1207-0302	EB-ML, EB-1215-0303	EB-ML, EB-12, EB-1207, EB-1207-03, EB-1215, EB-1215-03, EB-40 EB-44
ROAD STANDARD:	Construction	Reconstruction	Pre-Haul Maintenance
NUMBER OF STATIONS:	29.24	22.59	472.63
CLEARING & GRUBBING:	\$7,788	\$5,505	\$0
EXCAVATION & FILL:	\$27,658	\$24,425	\$0
MISC. MAINTENANCE:	\$0	\$0	\$23,909
ROAD ROCK:	\$62,033	\$45,935	\$0
ROCK STOCKPILE PROD:	\$0	\$0	\$0
CULVERTS & FABRIC:	\$18,877	\$2,560	\$0
STRUCTURES:	\$7,500	\$0	\$0
MOBILIZATION:	\$2,359	\$2,359	\$958
TOTAL COSTS:	\$126,214	\$80,784	\$24,867
COST PER STATION:	\$4,316	\$3,576	\$53
ROAD DEACTIVATION & ABANDONMENT COSTS:		\$334	
TOTAL (All Roads) =			\$232,199
ESTIMATED PRECRUISE SALE VOLUME MBF =			3200
ESTIMATED TOTAL \$/MBF =			\$72.56

Compiled by: J. Westra

Date: 12/14/2023

Road Summary

SUMMARY INFORMATION					
Prehaul Maintenance (ft)	47,263	Construction (ft)	2,924	Reconstruction (ft)	2,259
Abandonment (ft)	407	Subgrade (acres)	1.11	Subgrade (acres)	0.86
Ballast Rock (CY)	5,725	Steepest Side Slope	0%	Steepest Side Slope	0%
Rip Rap (CY)	119				

PREHAUL MAINTENANCE							
Road	From	To	STA		\$/STA	Total Cost	
EB-ML		0	1,627	16+27		\$30	\$489
EB-ML		5,118	30,673	255+55		\$30	\$7,683
EB-40		0	2,163	21+63		\$111	\$2,405
EB-44		0	2,480	24+80		\$111	\$2,758
				+			
EB-12		0	8,127	81+27		\$30	\$2,443
EB-1207		0	1,429	14+29		\$111	\$1,589
EB-1207-03		0	1,331	13+31		\$111	\$1,480
EB-1215		0	1,910	19+10		\$111	\$2,124
EB-1215-03		0	2,641	26+41		\$111	\$2,937
TOTAL			472+63				\$23,909

NEW CONSTRUCTION								
Road	From	To	STA	Side Slope	Subgrade Width	\$/STA	Total Cost	
EB-ML		1,627	3,985		23+58	16.50	\$4,415.13	\$104,109
					+			
EB-1207-03		1,331	1,625		2+94		\$3,156.45	\$9,280
					+			
EB-1207-0302		0	272		2+72		\$3,847.88	\$10,466
TOTAL			29+24					\$123,855

RECONSTRUCTION									
Road	From	To	STA	Side Slope	Subgrade Width	Current Width	\$/STA	Total Cost	
EB-ML		3,985	5,118		11+33	13.0	13.0	\$3,477.11	\$39,396
EB-ML		5431	5,846		4+15			\$3,609.96	\$14,981
EB-ML		25,263	25,670		4+07			\$4,634.42	\$18,862
					+				
EB-1215-0303		0	304		3+04			\$1,815.61	\$5,519

Road Summary

TOTAL

22+59

\$78,759

DRAFT

Prehaul Maintenance

Road	STA	Miles	Brushing	Brushing \$	Grading	Grading \$	Rock*	Misc Cost	Total
EB-ML	16+27.	0.31	Yes	\$489	No				\$489
EB-ML	255+55.	4.84	Yes	\$7,683	No				\$7,683
EB-40	21+63.	0.41	Yes	\$650	Yes	\$1,755			\$2,405
EB-44	24+80.	0.47	Yes	\$746	Yes	\$2,012			\$2,758
	+								
EB-12	81+27.	1.54	Yes	\$2,443	No				\$2,443
EB-1207	14+29.	0.27	Yes	\$430	Yes	\$1,159			\$1,589
EB-1207-03	13+31.	0.25	Yes	\$400	Yes	\$1,080			\$1,480
EB-1215	19+10.	0.36	Yes	\$574	Yes	\$1,550			\$2,124
EB-1215-03	26+41.	0.50	Yes	\$794	Yes	\$2,143			\$2,937
TOTAL				\$14,210		\$9,699			\$23,909

*See Rock Production sheet

DRAFT

Clearing and Grubbing

CONSTRUCTION

Road	Side Slope	Acres	Factor	\$/Acre*	\$/STA	Cost
EB-ML		2.08	1.2	\$2,600	\$275.76	\$6,502
EB-1207-03		0.26	1.2	\$1,300	\$137.88	\$405
EB-1207-0302		0.24	1.2	\$3,050	\$323.48	\$880
TOTAL						\$7,788

RECONSTRUCTION

Road	Side Slope	Acres	Factor	\$/Acre*	\$/STA	Cost
EB-ML		1.00	1.2	\$3,050	\$323.48	\$3,665
EB-ML		0.37	1.2	\$1,630	\$172.88	\$717
EB-ML		0.36	1.2	\$1,630	\$172.88	\$704
EB-1215-0303		0.27	1.2	\$1,300	\$137.88	\$419
TOTAL						\$5,505

Excavation and Shaping

CONSTRUCTION

Road	Full Bench	Approx. Volume	Waste Area (mi)	Endhaul Cost	STA	STA/DAY	TOTAL
EB-ML	Yes	3800	0.50	\$7,315	23+58	3	\$23,439
					+		
EB-1207-03	No				2+94	4	\$2,192
					+		
EB-1207-0302	No				2+72	4	\$2,028
							\$27,658

RECONSTRUCTION

Road	End Haul	Approx. Volume	Waste Area (mi)	Endhaul Cost	STA	STA/DAY	TOTAL
EB-ML	No				11+33	3	\$11,262
EB-ML	Yes	1500	1.00	\$3,713	4+15	2	\$6,188
EB-ML	No				4+07	2	\$6,068
					+		
EB-1215-0303	No				3+04	10	\$907
							\$24,425

DRAFT

Rock Production, Haul and Spread

PREHAUL MAINTENANCE

Road	Ballast Depth	CY / STA	Ballast	Stockpile	Haul Mi	Rip Rap	Stockpile	Haul Mi	\$/Load		Haul Cost	Spread Cost	Total Cost
									Prod Cost	Riprap			
EB-ML									\$13.75	\$13.75			
EB-ML									\$13.75	\$13.75			
EB-40									\$13.75	\$13.75			
EB-44									\$13.75	\$13.75			
									\$13.75	\$13.75			
EB-12									\$13.75	\$13.75			
EB-1207									\$13.75	\$13.75			
EB-1207-03									\$13.75	\$13.75			
EB-1215									\$13.75	\$13.75			
EB-1215-03									\$13.75	\$13.75			
TOTAL									\$0		\$0	\$0	\$0

CONSTRUCTION

Road	Ballast Depth	CY / STA	Ballast	Stockpile	Haul Mi	Rip Rap	Stockpile	Haul Mi	\$/Load		Haul Cost	Spread Cost	Total Cost	
									Prod Cost	Riprap				
EB-ML	18"	114	2,690	No	0.56	89		0.56	\$30,104	\$26.18	\$26.18	\$7,277	\$11,836	\$49,216
										\$13.75	\$13.75			
EB-1207-03	18"	114	335	No	1.33				\$3,749	\$42.94	\$13.75	\$1,460	\$1,474	\$6,683
										\$13.75	\$13.75			
EB-1207-0302	18"	114	310	No	1.22	10		1.22	\$3,469	\$40.64	\$40.64	\$1,300	\$1,364	\$6,134
			3,335			99			\$37,322			\$10,037	\$14,674	\$62,033

RECONSTRUCTION

Road	Ballast Depth	CY / STA	Ballast	Stockpile	Haul Mi	Rip Rap	Stockpile	Haul Mi	\$/Load		Haul Cost	Spread Cost	Total Cost	
									Prod Cost	Riprap				
EB-ML	18"	114	1,290	No	0.22	15			\$14,436	\$18.67	\$13.75	\$2,436	\$5,676	\$22,549
EB-ML	18"	114	475	No	0.01				\$5,316	\$13.97	\$13.75	\$671	\$2,090	\$8,076
EB-ML	18"	114	465	No	3.73				\$5,204	\$95.88	\$13.75	\$4,506	\$2,046	\$11,756
										\$13.75	\$13.75			
EB-1215-0303	9"	53	160	No	2.21	5		2.21	\$1,791	\$62.31	\$62.31	\$1,059	\$704	\$3,554
			2,390			20			\$26,746			\$8,673	\$10,516	\$45,935

Road Abandonment

CONSTRUCTION									
Road	Abandon	STA	Barriers	Culverts	Waterbars	Seed Acres		\$/STA	Cost
EB-ML	No		+						
			+						
EB-1207-03	No		+						
			+						
EB-1207-0302	No		+						
			+						

RECONSTRUCTION									
Road	Abandon	STA	Barriers	Culverts	Waterbars	Seed Acres		\$/STA	Cost
EB-ML	No		+						
EB-ML	No		+						
EB-TEMP	Yes	4+07.		2		2	0.01	\$82.04	\$334
			+						
EB-1215-0303	No		+						
		4+07.							\$334

DRAFT

Culverts

NEW CONSTRUCTION

Road	Round Culvert Pipe												Pipe-Arch				Total	
	18" # LF	24" # LF	30" # LF	36" # LF	42" # LF	48" # LF	54" # LF	60" # LF	66" # LF	72" # LF	84" # LF	96" # LF	54" # LF	60" # LF	72" # LF	84" # LF		
EB-ML	9	280	4	150	3	110												\$17,452
EB-1207-03																		
EB-1207-0302	2	70																\$1,425
TOTAL	11		4		3													\$18,877

RECONSTRUCTION

Road	Round Culvert Pipe												Pipe-Arch				Total	
	18" # LF	24" # LF	30" # LF	36" # LF	42" # LF	48" # LF	54" # LF	60" # LF	66" # LF	72" # LF	84" # LF	96" # LF	54" # LF	60" # LF	72" # LF	84" # LF		
EB-ML	3	90																\$1,920
EB-ML																		
EB-ML																		
EB-1215-0303	1	30																\$640
TOTAL	4																	\$2,560

Mobilization

Prehaul Maintenance 0.00 miles from gate

Equipment	#	Haul Rate	Gravel mph	Hours	Move In	Move Out	Comments
Brusher (80 PTO HP)	1	\$110.00	15	1	\$110	\$110	Truck and tilt trailer
Grader (175 HP)	3	\$123.00	5	1	\$369	\$369	Small lowboy.
Subtotal					\$479	\$479	

Construction/Reconstruction 4.00 miles from gate

Equipment	#	Haul Rate	Gravel mph	Hours	Move In	Move Out	Comments
Excavator (Large)	1	\$145.00	2	3	\$435	\$435	Large Lowboy
Truck (10CY Dual Axle)	3	\$98.00	20	2	\$588	\$588	Rate from 2015 ARRF
Cat (Medium: D5, 650J)	1	\$123.00	5	2	\$246	\$246	Small Lowboy
Grader (175 HP)		\$123.00	5	2			Small Lowboy.
Subtotal					\$1,269	\$1,269	

Pit 4.00 miles from gate

Equipment	#	Haul Rate	Gravel mph	Hours	Move In	Move Out	Comments
Rock Drill	1	\$110.00	15	2	\$220	\$220	Truck and tilt trailer. Half prehaul/construction
Jaw Crusher	1	\$145.00	2	3	\$435	\$435	Large lowboy. Half prehaul/construction
Front End Loader (Large)	1	\$145.00	2	3	\$435	\$435	Large lowboy. Half prehaul/construction
Subtotal					\$1,090	\$1,090	

City	Miles to Gate
Everett	30
Granite	20
Arlington	10
Sedro	35
Bham	60
Use pavement	30 miles 30 mph

Prehaul Mob	\$958
% of Project	0.41%
Construct/Reconstruct Mob	\$4,718
% of Project	2.07%
Total Mob	\$5,676
% of Project	2.51%