



**TIMBER NOTICE OF SALE**

**SALE NAME:** *STILLY REVISITED*

**AGREEMENT NO:** 30-93860

**AUCTION:** July 24, 2024 starting at 10:00 a.m.,  
Northwest Region Office, Sedro Woolley, WA

**COUNTY:** Snohomish

**SALE LOCATION:** Sale located approximately 13 miles northeast of Arlington, WA.

**PRODUCTS SOLD  
AND SALE AREA:**

All timber bounded by white timber sale boundary tags, except cedar salvage (cedar snags, preexisting dead and down cedar trees and cedar logs), trees marked with blue paint on the bole and root collar, and forest products tagged out by yellow leave tree area tags in Unit #1.

All timber bounded by white timber sale boundary tags and the ST-ML Road, except cedar salvage (cedar snags, preexisting dead and down cedar trees and cedar logs), trees marked with blue paint on the bole and root collar, and forest products tagged out by yellow leave tree area tags in Unit #2.

All timber bounded by white timber sale boundary tags, except cedar salvage (cedar snags, preexisting dead and down cedar trees and cedar logs) and trees marked with blue paint on the bole and root collar in Unit #3.

All timber bounded by white timber sale boundary tags and the ST-ML Road, except cedar salvage (cedar snags, preexisting dead and down cedar trees and cedar logs) and trees marked with blue paint on the bole and root collar in Unit #4.

All timber bounded by white timber sale boundary tags and the ST-37 Road, except cedar salvage (cedar snags, preexisting dead and down cedar trees and cedar logs), trees marked with blue paint on the bole and root collar, and forest products tagged out by yellow leave tree area tags in Unit #5.

All timber bounded by white timber sale boundary tags, property lines and the ST-37 Road, except cedar salvage (cedar snags, preexisting dead and down cedar trees and cedar logs), trees marked with blue paint on the bole and root collar, and forest products tagged out by yellow leave tree area tags in Unit #6.

All timber bounded by orange right-of-way tags and all timber within 30 feet of centerline of roads to be constructed.

All forest products above located on part(s) of Sections 3, 4 and 5 all in Township 32 North, Range 6 East, W.M., containing 152 acres, more or less.

**CERTIFICATION:** This sale is certified under the Sustainable Forestry Initiative® program Standard (cert no: BVC-SFIFM-018227)



**TIMBER NOTICE OF SALE**

**ESTIMATED SALE VOLUMES AND QUALITY:**

Species	Avg DBH	Ring Count	Total MBF	MBF by Grade								
				1P	2P	3P	SM	1S	2S	3S	4S	UT
Douglas fir	25.6	9	3,220			117	153		2,459	446	30	15
Hemlock	21.1		3,208						2,503	573	81	51
Silver fir	29.6		557						529	28		
Redcedar	20.6		460							421	39	
Red alder	17.2		373						181	100	88	4
Maple	18.5		112						57	43	9	3
<b>Sale Total</b>			<b>7,930</b>									

**MINIMUM BID:** \$0.00      **BID METHOD:** Sealed Bids

**PERFORMANCE SECURITY:** \$0.00      **SALE TYPE:** Lump Sum

**EXPIRATION DATE:** March 31, 2027      **ALLOCATION:** Export Restricted

**BID DEPOSIT:** \$0.00 or Bid Bond. Said deposit shall constitute an opening bid at the appraised price.

**HARVEST METHOD:** Cable OR tethered equipment (See below for restrictions); shovel, “6-wheeled rubber-tired skidders with over-the-tire tracks spanning both sets of rear tires” (See below for restrictions), tracked skidder or rubber-tired skidder on sustained slopes 35% or less; self-leveling equipment on sustained slopes 50% or less (See below for restrictions).

Prior written approval of the Contract Administrator is required before tethered or self-leveling equipment may be used. If ground disturbance is causing excessive damage, as determined by the Contract Administrator, the use of this equipment will no longer be authorized.

Purchaser must obtain prior written approval from the Contract Administrator for areas as to where “6 wheeled rubber tired skidders with over-the-tire tracks spanning both sets of rear tires” can operate. If ground disturbance is causing excessive damage, as determined by the Contract Administrator, the equipment will no longer be authorized. Falling and Yarding will not be permitted from November 1 to March 31 unless authorized in writing by the Contract Administrator (THIS PERTAINS TO GROUND-BASED EQUIPMENT ONLY) to reduce soil damage and erosion.

Additional restrictions apply, see Remarks section below.

**ROADS:** 56.86 stations of required construction. 26.14 stations of required reconstruction. 238.90 stations of required prehaul maintenance. 14.06 stations of abandonment.

Rock may be obtained from the following source on State land at no charge to the Purchaser: Oceanview Pit at station 2+71 of the ST-3702 Road.

Development of existing rock source will involve drilling, shooting, and processing rock to generate riprap, 2-inch-minus surfacing, and 3-inch-minus ballast rock.

An estimated total quantity of rock needed for this proposal: 180 cubic yards of riprap and 2,070 cubic yards of surfacing rock and 7,990 cubic yards of ballast rock.



## TIMBER NOTICE OF SALE

---

Additional restrictions apply, see Remarks section below.

Road work and the hauling of rock will not be permitted from November 1 to March 31 unless authorized in writing by the Contract Administrator to reduce soil damage and siltation. The hauling of forest products will not be permitted from November 1 to March 31 unless authorized in writing by the Contract Administrator to reduce soil damage and siltation.

### **ACREAGE DETERMINATION**

**CRUISE METHOD:** Acres determined by GPS traverse. Cruise was conducted via variable plot sample type. See Cruise Narrative for further details. Shapefiles of units are available upon request, and on the DNR website after the BNR meeting in which the sale is presented.

**FEES:** \$134,810.00 is due on day of sale. \$9.00 per MBF is due upon removal. These are in addition to the bid price.

**SPECIAL REMARKS:**

1. Trees marked with a pink "T" represent the last take tree along property line boundaries.
2. No hauling on weekends or federal holidays.
3. No hauling before 7:00 AM or after 5:00 PM.
4. No operations before 7:00 AM or after 5:00 PM within 100 feet of neighbors in Unit 6.
5. HQ DF noted within the sale area. See cruise for further details.

# TIMBER SALE MAP

**SALE NAME:** STILLY REVISITED  
**AGREEMENT #:** 30-093860  
**TOWNSHIP(S):** T32R6E  
**TRUST(S):** Agricultural School (4), State Forest Purchase (2), State Forest Transfer (1), Common School (3)

**REGION:** Northwest Region  
**COUNTY(S):** Snohomish  
**ELEVATION RGE:** 680-1960

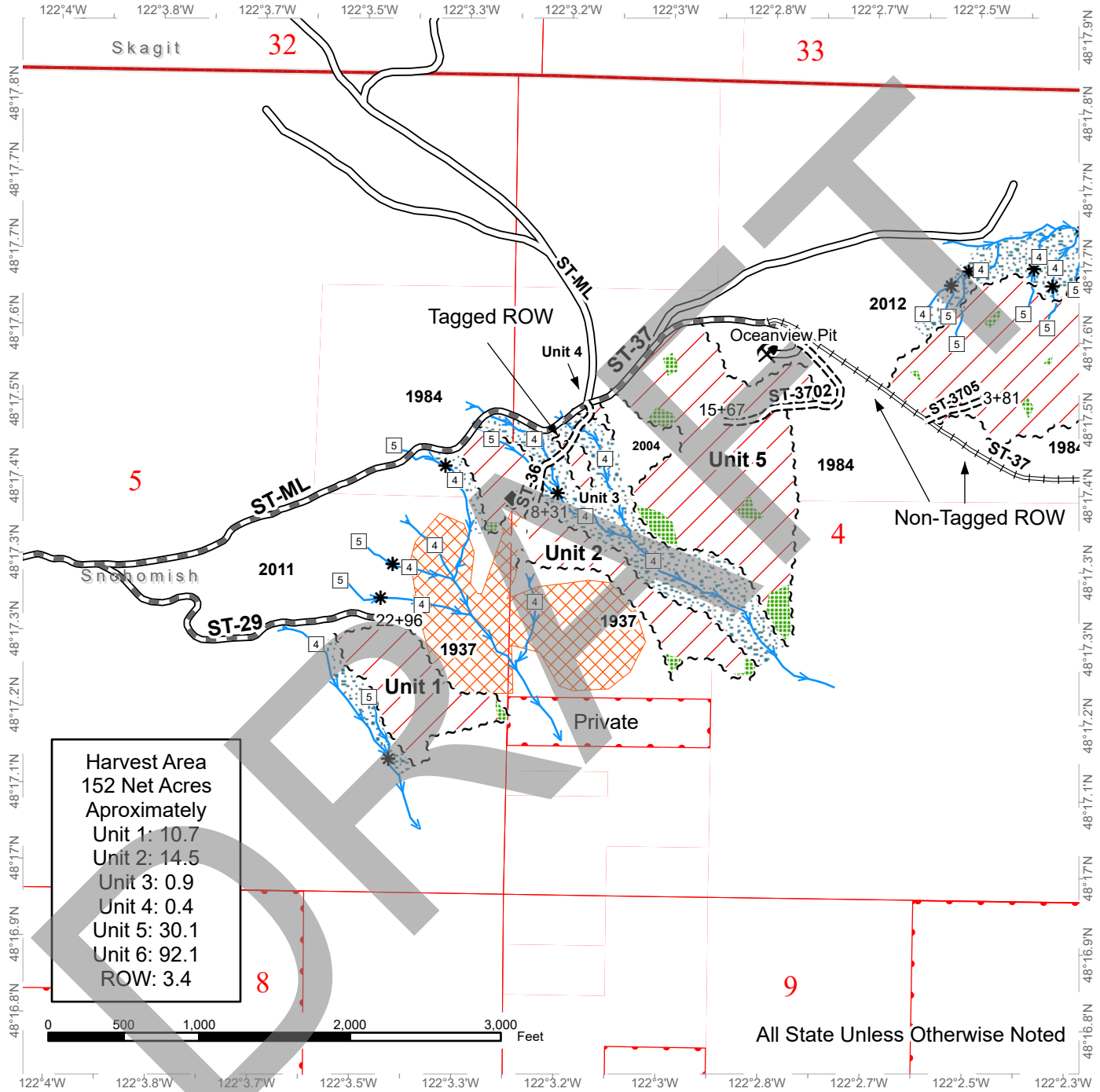

Harvest Area	
152 Net Acres	
Approximately	
Unit 1:	10.7
Unit 2:	14.5
Unit 3:	0.9
Unit 4:	0.4
Unit 5:	30.1
Unit 6:	92.1
ROW:	3.4

	Variable Retention Harvest		Stream Type 4		Required Pre-Haul Maintenance
	Sale Boundary Tags		Stream Type 5		Required Construction
	No Entry		Stream Break		Required Reconstruction
	Leave Tree Area		Survey Monument		DNR Managed Lands
	Riparian Mgt Zone		Rock Pit		
	Streams		Existing Roads		



# TIMBER SALE MAP

**SALE NAME:** STILLY REVISITED  
**AGREEMENT #:** 30-093860  
**TOWNSHIP(S):** T32R6E  
**TRUST(S):** Agricultural School (4), State Forest Purchase (2), State Forest Transfer (1), Common School (3)

**REGION:** Northwest Region  
**COUNTY(S):** Snohomish  
**ELEVATION RGE:** 680-1960

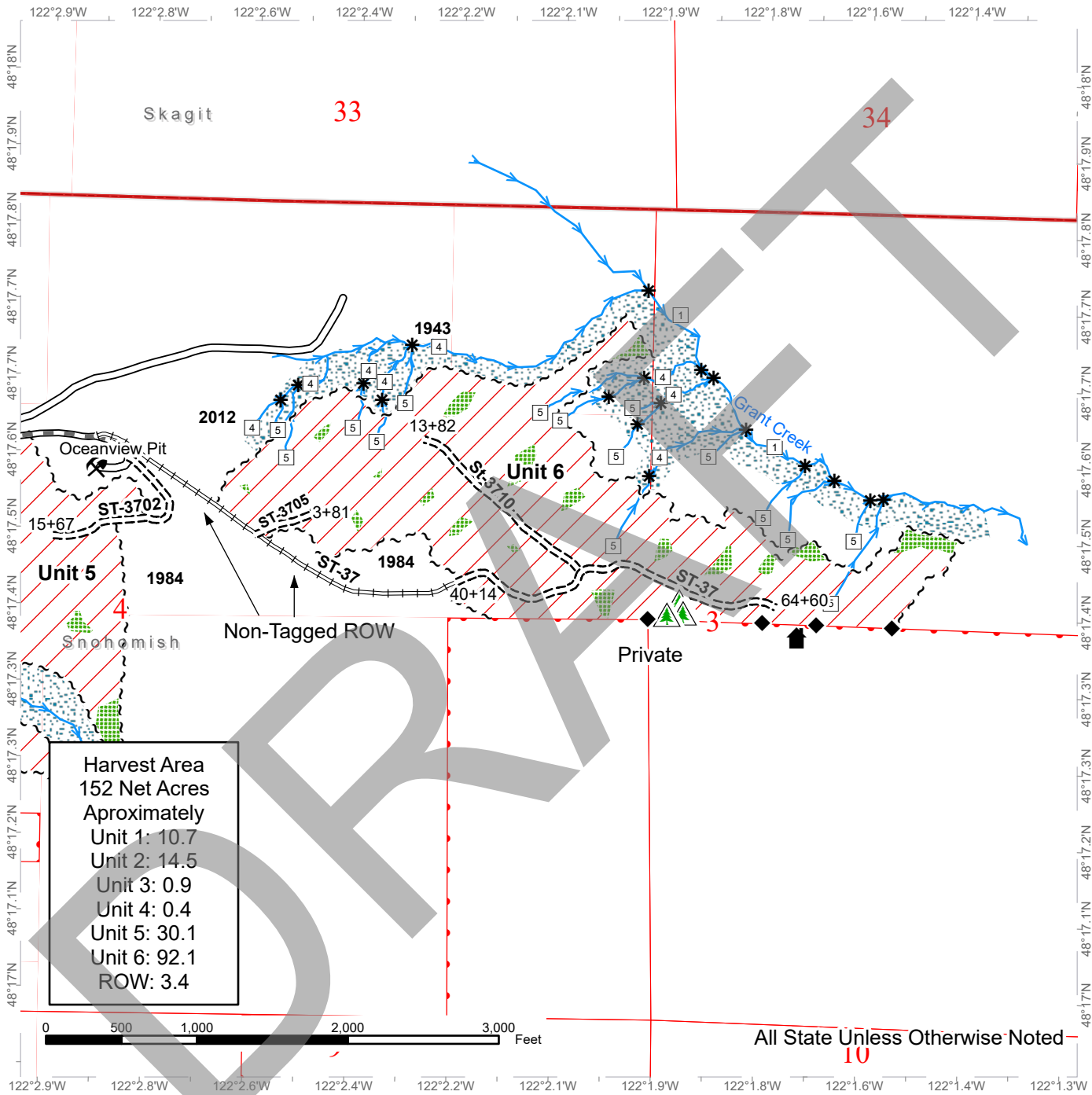

<b>Harvest Area</b>	
152 Net Acres	
Approximately	
Unit 1:	10.7
Unit 2:	14.5
Unit 3:	0.9
Unit 4:	0.4
Unit 5:	30.1
Unit 6:	92.1
ROW:	3.4

All State Unless Otherwise Noted

Variable Retention Harvest	Stream Type 5	Existing Roads
Sale Boundary Tags	Stream Break	Required Pre-Haul Maintenance
Leave Tree Area	Non-Tradeable Leave Trees	Required Construction
Riparian Mgt Zone	Survey Monument	Required Reconstruction
Streams	Rock Pit	DNR Managed Lands
Stream Type 1	Structure	
Stream Type 4		



# DRIVING MAP

**SALE NAME:** STILLY REVISITED  
**AGREEMENT#:** 30-093860  
**TOWNSHIP(S):** T32R6E  
**TRUST(S):** Agricultural School (4), Common School and Indemnity (3), State Forest Purchase (2), State Forest Transfer (1)

**REGION:** Northwest Region  
**COUNTY(S):** Snohomish  
**ELEVATION RGE:** 680-1960

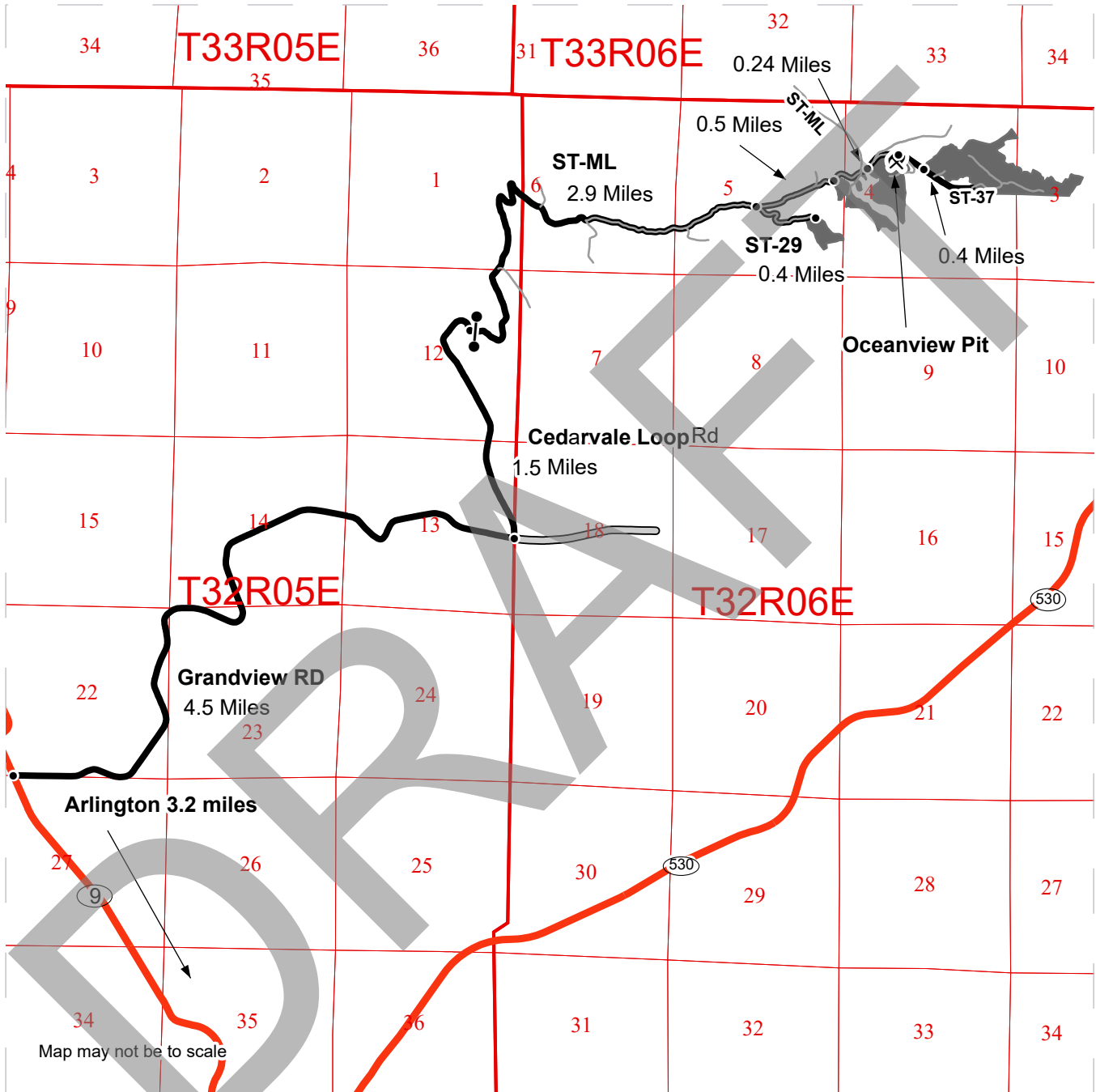

- Timber Sale Unit
- Haul Route
- Other Road
- Distance Indicator
- Gate (F1-3)
- Rock Pit

**Driving Directions:**  
 From Arlington: Travel north on HWY 9 for 3.2 miles. Turn right onto Grandview Rd and continue for 4.5 miles. Turn left onto Cedarvale Loop Rd, travel for 1.5 miles before reaching the ST- ML on the left side of the road.  
 Unit 1: From the junction of Cedarvale Loop Rd and the ST-ML, travel through the gate and along the ML for 2.9 miles. Turn right onto the ST-29 and continue for 0.4 miles before reaching unit 1.  
 Unit 2: From the junction of the ST-ML and ST-29 continue 0.5 miles, unit 2 will be on the right.  
 Unit 3, 4 & 5: From Unit 2, Continue on the ML and on the right will be Unit 3, Unit 4 and Unit 5.  
 Unit 6: From the junction of the ST-ML and ST-37, continue on the ST-37 for 0.4 miles to reach the start of unit 6.  
 Oceanview Rockpit: From the junction ST-ML and ST-37, continue 0.2 miles to the ST-3702. Drive for 0.1 miles to reach the rockpit.



## Timber Sale Cruise Report Stilly Revisited - NW

**Sale Name:** STILLY REVISITED

**Sale Type:** LUMP SUM

**Region:** NORTHWEST

**District:** CLEAR LAKE

**Lead Cruiser:** Matt Llobet

**Other Cruisers:** Bailey Vos

Stilly Revisited is located north of Arlington off the Grandview Road. It consists of 6 units and includes one Right of Way (ROW). Topography is a combination of steep cable gradient and flat ground harvest areas. Forest roads provide drive access to most of the sale, but unit 6 requires a short hike to reach.

My total net cruise volume for Stilly Revisited is 7,930 MBF. Most of the sale contains a variable stocked Douglas-fir and western hemlock component in the medium-large diameter range. Common defects seen throughout the sale are spike knots, sway, and crooks.

For this cruise different basal area factors were selected based on stocking levels, tree sizes, and understory conditions. My plots were generated in GIS and located in the field using Avenza. Bole height was measured with a laser and taken to a 5" top or break point (40% of diameter at 16 feet). Trees were segmented into appropriate west-side log lengths and defect was accounted for accordingly at each cruise plot.

### Timber Sale Notice Volume (MBF)

Sp	DBH	Rings/In	Age	MBF Volume by Grade						
				All	Peeler	Spec Mill	2 Saw	3 Saw	4 Saw	Utility
DF	25.6	9.2		3,220	117	153	2,459	446	30	15
WH	21.1			3,208			2,503	573	81	51
SF	29.6			557			529	28		
RC	20.6			460				421	39	
RA	17.2			373			181	100	88	4
MA	18.5			112			57	43	9	3
ALL	21.9	9.1		7,930	117	153	5,729	1,611	247	73

### Timber Sale Notice Weight (tons)

Sp	Tons by Grade						
	All	Peeler	Spec Mill	2 Saw	3 Saw	4 Saw	Utility
WH	23,494			17,197	5,104	834	359
DF	18,932	598	938	13,845	3,236	229	85
RC	3,358				2,995	363	
SF	3,288			3,065	222		
RA	2,679			1,105	775	759	39
MA	854			404	347	82	21
ALL	52,604	598	938	35,617	12,679	2,267	504

**Timber Sale Overall Cruise Statistics**

BA (sq ft/acre)	BA SE (%)	V-BAR (bf/sq ft)	V-BAR SE (%)	Net Vol (bf/acre)	Vol SE (%)
264.5	4.6	195.8	2.3	52,136	5.0

**Timber Sale Unit Cruise Design**

Unit	Design	Cruise Acres	FMA Acres	N Plots	N Cruise Plots	N Void Plots
STILLY REVISITED 1	B2: VR, 2 BAF (62.5, 40 for some species) Measure All, Sighting Ht = 4.5 ft	10.7	10.9	10	10	0
STILLY REVISITED 2	B2: VR, 2 BAF (62.5, 40 for some species) Measure All, Sighting Ht = 4.5 ft	14.5	15.2	10	10	0
STILLY REVISITED 3	FX: FR plots (20 tree / acre expansion)	0.9	0.9	1	1	0
STILLY REVISITED 4	FX: FR plots (20 tree / acre expansion)	0.4	0.5	1	1	0
STILLY REVISITED 5	B2: VR, 2 BAF (62.5, 40 for some species) Measure All, Sighting Ht = 4.5 ft	30.1	33.1	19	19	0
STILLY REVISITED 6	B2C: VR, 2 BAF (62.5, 40 for some species) Measure/Count Plots, Sighting Ht = 4.5 ft	92.1	97.5	48	27	1
STILLY REVISITED ROW	FX: FR plots (20 tree / acre expansion)	3.4	3.5	5	5	0
All		152.1	161.5	94	73	1

**Timber Sale Log Grade x Sort Summary**

Sp	Status	Grade	Sort	Dia	Len	BF Gross	BF Net	Defect %	Tons	MBF Net
DF	LIVE	2 SAW	Domestic	17.6	39	12,427	12,368	0.5	10,669.9	1,881.1
DF	LIVE	2 SAW	HQ-A	21.6	40	899	899	0.0	781.4	136.7
DF	LIVE	2 SAW	HQ-B	21.5	40	2,908	2,901	0.3	2,394.1	441.3
DF	LIVE	3 PEELER	HQ-A	26.7	37	771	771	0.0	598.4	117.3
DF	LIVE	3 SAW	Domestic	9.3	36	2,944	2,934	0.3	3,235.6	446.3
DF	LIVE	4 SAW	Domestic	7.3	22	194	194	0.0	229.5	29.6
DF	LIVE	SPECIAL MILL	HQ-A	18.3	40	1,004	1,004	0.0	938.2	152.7
DF	LIVE	UTILITY	Pulp	8.8	31	98	98	0.0	85.3	14.9
MA	LIVE	2 SAW	Domestic	15.7	28	407	377	7.2	403.7	57.4
MA	LIVE	3 SAW	Domestic	11.3	30	281	281	0.0	346.8	42.7



Sp	Status	Grade	Sort	Dia	Len	BF Gross	BF Net	Defect %	Tons	MBF Net
MA	LIVE	4 SAW	Domestic	8.1	25	59	59	0.0	82.3	9.0
MA	LIVE	UTILITY	Pulp	11.0	20	19	19	0.0	20.7	2.9
RA	LIVE	2 SAW	Domestic	14.8	30	1,216	1,192	2.0	1,105.1	181.3
RA	LIVE	3 SAW	Domestic	11.3	30	684	656	4.1	775.1	99.7
RA	LIVE	4 SAW	Domestic	8.7	24	579	579	0.0	759.2	88.1
RA	LIVE	UTILITY	Pulp	10.8	20	28	28	0.0	39.4	4.2
RC	LIVE	3 SAW	Domestic	12.8	37	2,474	2,436	1.5	2,577.5	370.5
RC	LIVE	3 SAW	Pole	10.1	52	332	332	0.0	417.5	50.4
RC	LIVE	4 SAW	Domestic	6.9	24	256	256	0.0	362.7	38.9
RC	LIVE	CULL	Cull	24.9	25	194	0	100.0	0.0	0.0
SF	LIVE	2 SAW	Domestic	17.9	38	3,571	3,475	2.7	3,065.3	528.6
SF	LIVE	3 SAW	Domestic	9.7	28	185	185	0.0	222.3	28.2
WH	LIVE	2 SAW	Domestic	16.6	39	16,873	16,457	2.5	17,197.2	2,503.0
WH	LIVE	3 SAW	Domestic	9.0	35	3,827	3,768	1.5	5,103.8	573.1
WH	LIVE	4 SAW	Domestic	7.1	23	549	534	2.7	833.8	81.2
WH	LIVE	CULL	Cull	22.6	18	506	0	100.0	0.0	0.0
WH	LIVE	UTILITY	Pulp	15.0	28	349	333	4.5	359.1	50.7

### Timber Sale Log Sort x Diameter Bin Summary

Sp	Bin	Status	Sort	Dia	Len	BF Net	Defect %	Tons	MBF Net
DF	5 - 7	LIVE	Pulp	6.2	27	28	0.0	30.7	4.2
DF	5 - 7	LIVE	Domestic	6.9	30	541	0.0	614.2	82.3
DF	8 - 11	LIVE	Domestic	9.8	36	2,529	0.4	2,790.4	384.6
DF	12 - 15	LIVE	Domestic	13.7	39	3,802	0.1	3,790.5	578.2
DF	12 - 15	LIVE	HQ-B	15.8	40	52	0.0	44.2	7.9
DF	16 - 19	LIVE	HQ-B	17.6	40	988	0.0	857.3	150.3
DF	16 - 19	LIVE	HQ-A	17.7	40	1,034	0.0	982.6	157.2
DF	16 - 19	LIVE	Domestic	17.9	40	3,149	1.0	2,691.4	479.0
DF	20+	LIVE	Domestic	24.0	40	5,475	0.4	4,248.5	832.8
DF	20+	LIVE	HQ-B	24.1	40	1,861	0.4	1,492.6	283.1
DF	20+	LIVE	HQ-A	24.2	39	1,640	0.0	1,335.3	249.5
DF	20+	LIVE	Pulp	33.1	24	71	0.0	54.6	10.7
MA	5+	LIVE	Pulp	11.0	20	19	0.0	20.7	2.9
MA	5+	LIVE	Domestic	11.7	29	717	3.9	832.8	109.0
RA	5+	LIVE	Domestic	9.9	27	2,427	2.1	2,639.4	369.1
RA	5+	LIVE	Pulp	10.8	20	28	0.0	39.4	4.2
RC	5+	LIVE	Domestic	9.8	31	2,692	1.4	2,940.2	409.4

Sp	Bin	Status	Sort	Dia	Len	BF Net	Defect %	Tons	MBF Net
RC	5+	LIVE	Pole	10.1	52	332	0.0	417.5	50.4
RC	5+	LIVE	Cull	23.7	29	0	100.0	0.0	0.0
SF	5 - 7	LIVE	Domestic	7.2	32	17	0.0	25.0	2.5
SF	8 - 11	LIVE	Domestic	10.4	28	140	0.0	170.0	21.3
SF	12 - 15	LIVE	Domestic	13.4	35	553	0.0	570.2	84.2
SF	16 - 19	LIVE	Domestic	18.2	39	1,327	0.6	1,170.8	201.9
SF	20+	LIVE	Domestic	23.8	39	1,623	5.1	1,351.5	246.8
WH	5 - 7	LIVE	Domestic	6.7	30	1,177	0.6	1,756.0	179.0
WH	8 - 11	LIVE	Pulp	9.6	24	21	0.0	33.9	3.2
WH	8 - 11	LIVE	Domestic	10.0	33	3,009	2.1	4,042.8	457.7
WH	8 - 11	LIVE	Cull	11.6	14	0	100.0	0.0	0.0
WH	12 - 15	LIVE	Pulp	12.0	32	18	47.1	48.3	2.7
WH	12 - 15	LIVE	Domestic	14.0	39	5,095	1.2	6,014.7	774.9
WH	16 - 19	LIVE	Domestic	17.5	40	6,422	2.5	6,723.4	976.8
WH	16 - 19	LIVE	Pulp	19.1	24	75	0.0	63.5	11.3
WH	20+	LIVE	Domestic	23.3	40	5,055	3.6	4,597.9	768.9
WH	20+	LIVE	Pulp	30.3	40	220	0.0	213.3	33.5
WH	20+	LIVE	Cull	33.2	22	0	100.0	0.0	0.0

## Cruise Unit Report STILLY REVISITED 1

### Unit Sale Notice Volume (MBF): STILLY REVISITED 1

Sp	DBH	Rings/In	Age	MBF Volume by Grade			
				All	2 Saw	3 Saw	4 Saw
DF	19.1			612	427	180	5
RC	12.2			3		3	
ALL	18.9			615	427	183	5

### Unit Cruise Design: STILLY REVISITED 1

Design	Cruise Acres	FMA Acres	N Plots	N Cruise Plots	N Void Plots
B2: VR, 2 BAF (62.5, 40 for some species) Measure All, Sighting Ht = 4.5 ft	10.7	10.9	10	10	0

### Unit Cruise Summary: STILLY REVISITED 1

Sp	Cruised Trees	All Trees	Trees/Plot	Ring-Count Trees
DF	42	42	4.2	0
RC	1	1	0.1	0
ALL	43	43	4.3	0

### Unit Cruise Statistics: STILLY REVISITED 1

Sp	BA (sq ft/acre)	BA CV (%)	BA SE (%)	V-BAR (bf/sq ft)	V-BAR CV (%)	V-BAR SE (%)	Net Vol (bf/acre)	Vol CV (%)	Vol SE (%)
DF	262.5	38.6	12.2	218.1	29.5	4.6	57,239	48.6	13.0
RC	4.0	316.2	100.0	70.2	0.0	0.0	281	316.2	100.0
ALL	266.5	39.1	12.4	215.8	31.3	4.8	57,520	50.0	13.2

### Unit Summary: STILLY REVISITED 1

Sp	Status	Rx	N	D	DBH	BL	THT	BF Gross	BF Net	Defect %	TPA	BA	RD	MBF Net
DF	LIVE	CUT	42	ALL	19.1	95	128	57,432	57,239	0.3	131.9	262.5	60.1	612.5
RC	LIVE	CUT	1	ALL	12.2	39	60	281	281	0.0	4.9	4.0	1.1	3.0
ALL	LIVE	CUT	43	ALL	18.9	93	125	57,712	57,520	0.3	136.8	266.5	61.2	615.5
ALL	ALL	ALL	43	ALL	18.9	93	125	57,712	57,520	0.3	136.8	266.5	61.2	615.5

## Cruise Unit Report STILLY REVISITED 2

### Unit Sale Notice Volume (MBF): STILLY REVISITED 2

Sp	DBH	Rings/In	Age	MBF Volume by Grade			
				All	2 Saw	3 Saw	4 Saw
DF	20.3	9.0		807	607	183	16
WH	16.4			79	46	30	4
RC	11.9			21		14	7
MA	15.9			10		10	
ALL	18.7	9.0		917	653	236	27

### Unit Cruise Design: STILLY REVISITED 2

Design	Cruise Acres	FMA Acres	N Plots	N Cruise Plots	N Void Plots
B2: VR, 2 BAF (62.5, 40 for some species) Measure All, Sighting Ht = 4.5 ft	14.5	15.2	10	10	0

### Unit Cruise Summary: STILLY REVISITED 2

Sp	Cruised Trees	All Trees	Trees/Plot	Ring-Count Trees
DF	38	38	3.8	1
WH	5	5	0.5	0
RC	4	4	0.4	0
MA	2	2	0.2	0
ALL	49	49	4.9	1

### Unit Cruise Statistics: STILLY REVISITED 2

Sp	BA (sq ft/acre)	BA CV (%)	BA SE (%)	V-BAR (bf/sq ft)	V-BAR CV (%)	V-BAR SE (%)	Net Vol (bf/acre)	Vol CV (%)	Vol SE (%)
DF	237.5	44.4	14.0	234.4	24.9	4.0	55,671	50.9	14.6
WH	31.3	141.4	44.7	174.8	42.0	18.8	5,463	147.5	48.5
RC	16.0	241.5	76.4	89.3	57.4	28.7	1,428	248.3	81.6
MA	8.0	210.8	66.7	82.9	6.0	4.3	663	210.9	66.8
ALL	292.8	21.4	6.8	216.0	35.1	5.0	63,226	41.1	8.4

**Unit Summary: STILLY REVISITED 2**

Sp	Status	Rx	N	D	DBH	BL	THT	BF Gross	BF Net	Defect %	TPA	BA	RD	MBF Net
DF	LIVE	CUT	38	ALL	20.3	99	135	56,158	55,671	0.9	105.7	237.5	52.7	807.2
MA	LIVE	CUT	2	ALL	15.9	57	94	663	663	0.0	5.8	8.0	2.0	9.6
RC	LIVE	CUT	4	ALL	11.9	37	60	1,428	1,428	0.0	20.7	16.0	4.6	20.7
WH	LIVE	CUT	5	ALL	16.4	77	96	5,463	5,463	0.0	21.3	31.3	7.7	79.2
ALL	LIVE	CUT	49	ALL	18.7	86	118	63,713	63,226	0.8	153.5	292.8	67.1	916.8
ALL	ALL	ALL	49	ALL	18.7	86	118	63,713	63,226	0.8	153.5	292.8	67.1	916.8

DRAFT

## Cruise Unit Report STILLY REVISITED 3

### Unit Sale Notice Volume (MBF): STILLY REVISITED 3

Sp	DBH	Rings/In	Age	MBF Volume by Grade		
				All	2 Saw	3 Saw
WH	18.1			24	10	15
SF	24.2			14	8	5
ALL	19.5			38	18	20

### Unit Cruise Design: STILLY REVISITED 3

Design	Cruise Acres	FMA Acres	N Plots	N Cruise Plots	N Void Plots
FX: FR plots (20 tree / acre expansion)	0.9	0.9	1	1	0

### Unit Cruise Summary: STILLY REVISITED 3

Sp	Cruised Trees	All Trees	Trees/Plot	Ring-Count Trees
WH	3	4	4.0	0
SF	1	1	1.0	0
ALL	4	5	5.0	0

### Unit Cruise Statistics: STILLY REVISITED 3

Sp	BA (sq ft/acre)	BA CV (%)	BA SE (%)	V-BAR (bf/sq ft)	V-BAR CV (%)	V-BAR SE (%)	Net Vol (bf/acre)	Vol CV (%)	Vol SE (%)
WH	142.7	0.0	0.0	187.8	47.8	27.6	26,800	47.8	27.6
SF	63.9	0.0	0.0	238.3	0.0	0.0	15,220	0.0	0.0
ALL	206.6	0.0	0.0	203.4	40.9	20.5	42,020	40.9	20.5

### Unit Summary: STILLY REVISITED 3

Sp	Status	Rx	N	D	DBH	BL	THT	BF Gross	BF Net	Defect %	TPA	BA	RD	MBF Net
SF	LIVE	CUT	1	ALL	24.2	112	145	15,220	15,220	0.0	20.0	63.9	13.0	13.7
WH	LIVE	CUT	3	ALL	18.1	84	105	28,400	26,800	5.6	79.9	142.7	33.5	24.1
ALL	LIVE	CUT	4	ALL	19.5	89	113	43,620	42,020	3.7	99.9	206.6	46.5	37.8
ALL	ALL	ALL	4	ALL	19.5	89	113	43,620	42,020	3.7	99.9	206.6	46.5	37.8

## Cruise Unit Report STILLY REVISITED 4

### Unit Sale Notice Volume (MBF): STILLY REVISITED 4

Sp	DBH	Rings/In	Age	MBF Volume by Grade			
				All	2 Saw	3 Saw	4 Saw
SF	27.0			7	6	1	
WH	15.0			3		2	1
RC	23.5			3		3	
ALL	20.8			13	6	7	1

### Unit Cruise Design: STILLY REVISITED 4

Design	Cruise Acres	FMA Acres	N Plots	N Cruise Plots	N Void Plots
FX: FR plots (20 tree / acre expansion)	0.4	0.5	1	1	0

### Unit Cruise Summary: STILLY REVISITED 4

Sp	Cruised Trees	All Trees	Trees/Plot	Ring-Count Trees
SF	1	1	1.0	0
WH	1	2	2.0	0
RC	1	1	1.0	0
ALL	3	4	4.0	0

### Unit Cruise Statistics: STILLY REVISITED 4

Sp	BA (sq ft/acre)	BA CV (%)	BA SE (%)	V-BAR (bf/sq ft)	V-BAR CV (%)	V-BAR SE (%)	Net Vol (bf/acre)	Vol CV (%)	Vol SE (%)
SF	79.5	0.0	0.0	222.3	0.0	0.0	17,680	0.0	0.0
WH	49.1	0.0	0.0	158.1	0.0	0.0	7,760	0.0	0.0
RC	60.2	0.0	0.0	127.8	0.0	0.0	7,700	0.0	0.0
ALL	188.8	0.0	0.0	175.5	27.5	15.9	33,140	27.5	15.9

### Unit Summary: STILLY REVISITED 4

Sp	Status	Rx	N	D	DBH	BL	THT	BF Gross	BF Net	Defect %	TPA	BA	RD	MBF Net
RC	LIVE	CUT	1	ALL	23.5	74	94	7,700	7,700	0.0	20.0	60.2	12.4	3.1
SF	LIVE	CUT	1	ALL	27.0	112	145	20,480	17,680	13.7	20.0	79.5	15.3	7.1
WH	LIVE	CUT	1	ALL	15.0	70	92	7,760	7,760	0.0	40.0	49.1	12.7	3.1
ALL	LIVE	CUT	3	ALL	20.8	82	106	35,940	33,140	7.8	80.0	188.8	40.4	13.3

Sp	Status	Rx	N	D	DBH	BL	THT	BF Gross	BF Net	Defect %	TPA	BA	RD	MBF Net
ALL	ALL	ALL	3	ALL	20.8	82	106	35,940	33,140	7.8	80.0	188.8	40.4	13.3

DRAFT



## Cruise Unit Report STILLY REVISITED 5

### Unit Sale Notice Volume (MBF): STILLY REVISITED 5

Sp	DBH	Rings/In	Age	MBF Volume by Grade						
				All	Peeler	Spec Mill	2 Saw	3 Saw	4 Saw	Utility
DF	29.3	9.3		1,520	100	153	1,179	68	6	15
WH	19.3			364			249	85	19	11
RC	29.6			44				44		
SF	29.7			38			33	5		
ALL	25.3	9.3		1,965	100	153	1,462	201	24	26

### Unit Cruise Design: STILLY REVISITED 5

Design	Cruise Acres	FMA Acres	N Plots	N Cruise Plots	N Void Plots
B2: VR, 2 BAF (62.5, 40 for some species) Measure All, Sighting Ht = 4.5 ft	30.1	33.1	19	19	0

### Unit Cruise Summary: STILLY REVISITED 5

Sp	Cruised Trees	All Trees	Trees/Plot	Ring-Count Trees
DF	56	56	2.9	3
WH	22	22	1.2	0
RC	6	6	0.3	0
SF	2	2	0.1	0
ALL	86	86	4.5	3

### Unit Cruise Statistics: STILLY REVISITED 5

Sp	BA (sq ft/acre)	BA CV (%)	BA SE (%)	V-BAR (bf/sq ft)	V-BAR CV (%)	V-BAR SE (%)	Net Vol (bf/acre)	Vol CV (%)	Vol SE (%)
DF	184.2	80.3	18.4	274.0	22.1	3.0	50,483	83.3	18.7
WH	72.4	112.5	25.8	167.1	30.1	6.4	12,093	116.4	26.6
RC	12.6	259.7	59.6	114.8	55.8	22.8	1,451	265.6	63.8
SF	6.6	435.9	100.0	191.7	2.2	1.6	1,261	435.9	100.0
ALL	275.8	38.2	8.8	236.7	34.1	3.7	65,288	51.2	9.5

**Unit Summary: STILLY REVISITED 5**

Sp	Status	Rx	N	D	DBH	BL	THT	BF Gross	BF Net	Defect %	TPA	BA	RD	MBF Net
DF	LIVE	CUT	56	ALL	29.3	114	147	50,515	50,483	0.1	39.3	184.2	34.0	1,519.5
RC	LIVE	CUT	6	ALL	29.6	82	105	1,802	1,451	19.5	2.6	12.6	2.3	43.7
SF	LIVE	CUT	2	ALL	29.7	94	121	1,360	1,261	7.3	1.4	6.6	1.2	38.0
WH	LIVE	CUT	22	ALL	19.3	75	94	12,483	12,093	3.1	35.6	72.4	16.5	364.0
ALL	LIVE	CUT	86	ALL	25.3	95	121	66,160	65,288	1.3	78.9	275.8	54.0	1,965.2
ALL	ALL	ALL	86	ALL	25.3	95	121	66,160	65,288	1.3	78.9	275.8	54.0	1,965.2

DRAFT

## Cruise Unit Report STILLY REVISITED 6

### Unit Sale Notice Volume (MBF): STILLY REVISITED 6

Sp	DBH	Rings/In	Age	MBF Volume by Grade					
				All	Peeler	2 Saw	3 Saw	4 Saw	Utility
WH	21.5			2,737		2,198	441	58	39
SF	29.4			470		453	17		
RC	20.1			381			350	31	
RA	17.3			370		181	100	84	4
DF	36.5	9.0		269	18	245	6		
MA	18.7			102		57	33	9	3
ALL	21.6	9.0		4,328	18	3,135	946	183	47

### Unit Cruise Design: STILLY REVISITED 6

Design	Cruise Acres	FMA Acres	N Plots	N Cruise Plots	N Void Plots
B2C: VR, 2 BAF (62.5, 40 for some species) Measure/Count Plots, Sighting Ht = 4.5 ft	92.1	97.5	48	27	1

### Unit Cruise Summary: STILLY REVISITED 6

Sp	Cruised Trees	All Trees	Trees/Plot	Ring-Count Trees
WH	65	113	2.4	0
SF	12	15	0.3	0
RC	25	45	0.9	0
RA	15	42	0.9	0
DF	8	8	0.2	1
MA	11	16	0.3	0
ALL	136	239	5.0	1

### Unit Cruise Statistics: STILLY REVISITED 6

Sp	BA (sq ft/acre)	BA CV (%)	BA SE (%)	V-BAR (bf/sq ft)	V-BAR CV (%)	V-BAR SE (%)	Net Vol (bf/acre)	Vol CV (%)	Vol SE (%)
WH	147.1	97.8	14.1	202.0	28.8	3.6	29,715	101.9	14.6
SF	19.5	248.4	35.8	261.1	12.2	3.5	5,099	248.7	36.0
RC	37.5	138.1	19.9	110.3	40.5	8.1	4,136	143.9	21.5
RA	35.0	152.1	22.0	114.7	23.0	5.9	4,013	153.8	22.7
DF	10.4	484.7	70.0	280.1	9.3	3.3	2,917	484.7	70.0

Sp	BA (sq ft/acre)	BA CV (%)	BA SE (%)	V-BAR (bf/sq ft)	V-BAR CV (%)	V-BAR SE (%)	Net Vol (bf/acre)	Vol CV (%)	Vol SE (%)
MA	13.3	257.6	37.2	83.4	15.3	4.6	1,112	258.1	37.5
ALL	262.9	47.3	6.8	178.7	42.2	3.6	46,993	63.4	7.7

**Unit Summary: STILLY REVISITED 6**

Sp	Status	Rx	N	D	DBH	BL	THT	BF Gross	BF Net	Defect %	TPA	BA	RD	MBF Net
DF	LIVE	CUT	8	ALL	36.5	126	163	2,934	2,917	0.6	1.4	10.4	1.7	268.7
MA	LIVE	CUT	11	ALL	16.3	60	73	1,160	1,112	4.2	9.2	13.3	3.3	102.4
RA	LIVE	CUT	15	ALL	17.0	62	78	4,099	4,013	2.1	22.2	35.0	8.5	369.6
RC	LIVE	CUT	25	ALL	21.6	66	83	4,406	4,136	6.1	14.7	37.5	8.1	380.9
SF	LIVE	CUT	12	ALL	30.1	114	146	5,214	5,099	2.2	4.0	19.5	3.6	469.6
WH	LIVE	CUT	65	ALL	20.8	87	109	31,243	29,715	4.9	62.4	147.1	32.3	2,736.8
ALL	LIVE	CUT	136	ALL	20.6	79	99	49,056	46,993	4.2	113.9	262.9	57.4	4,328.0
ALL	ALL	ALL	136	ALL	20.6	79	99	49,056	46,993	4.2	113.9	262.9	57.4	4,328.0

DRAFT

## Cruise Unit Report STILLY REVISITED ROW

### Unit Sale Notice Volume (MBF): STILLY REVISITED ROW

Sp	DBH	Rings/In	Age	MBF Volume by Grade				
				All	2 Saw	3 Saw	4 Saw	Utility
SF	36.8			28	28			
DF	14.1	6.0		12		10	2	0
RC	18.9			8		8	1	
RA	8.9			4			4	
WH	10.5			1		1		
ALL	15.1	6.0		53	28	18	6	0

### Unit Cruise Design: STILLY REVISITED ROW

Design	Cruise Acres	FMA Acres	N Plots	N Cruise Plots	N Void Plots
FX: FR plots (20 tree / acre expansion)	3.4	3.5	5	5	0

### Unit Cruise Summary: STILLY REVISITED ROW

Sp	Cruised Trees	All Trees	Trees/Plot	Ring-Count Trees
SF	1	1	0.2	0
DF	8	8	1.6	1
RC	3	3	0.6	0
RA	8	8	1.6	0
WH	1	1	0.2	0
ALL	21	21	4.2	1

### Unit Cruise Statistics: STILLY REVISITED ROW

Sp	BA (sq ft/acre)	BA CV (%)	BA SE (%)	V-BAR (bf/sq ft)	V-BAR CV (%)	V-BAR SE (%)	Net Vol (bf/acre)	Vol CV (%)	Vol SE (%)
SF	29.5	223.6	100.0	282.6	0.0	0.0	8,348	223.6	100.0
DF	34.9	135.3	60.5	100.6	25.8	9.1	3,512	137.8	61.2
RC	23.5	223.6	100.0	105.3	9.1	5.3	2,472	223.8	100.1
RA	13.9	162.1	72.5	78.0	8.1	2.9	1,084	162.3	72.6
WH	2.4	223.6	100.0	104.7	0.0	0.0	252	223.6	100.0
ALL	104.2	95.3	42.6	150.3	30.7	6.7	15,668	100.1	43.1

**Unit Summary: STILLY REVISITED ROW**

Sp	Status	Rx	N	D	DBH	BL	THT	BF Gross	BF Net	Defect %	TPA	BA	RD	MBF Net
DF	LIVE	CUT	8	ALL	14.1	51	74	3,512	3,512	0.0	32.2	34.9	9.3	11.9
RA	LIVE	CUT	8	ALL	8.9	34	66	1,084	1,084	0.0	32.2	13.9	4.7	3.7
RC	LIVE	CUT	3	ALL	18.9	66	83	2,472	2,472	0.0	12.0	23.5	5.4	8.4
SF	LIVE	CUT	1	ALL	36.8	109	140	8,348	8,348	0.0	4.0	29.5	4.9	28.4
WH	LIVE	CUT	1	ALL	10.5	44	70	252	252	0.0	4.0	2.4	0.7	0.9
ALL	LIVE	CUT	21	ALL	15.0	49	75	15,668	15,668	0.0	84.4	104.2	25.0	53.3
ALL	ALL	ALL	21	ALL	15.0	49	75	15,668	15,668	0.0	84.4	104.2	25.0	53.3

DRAFT

# Stilly Revisited - NW

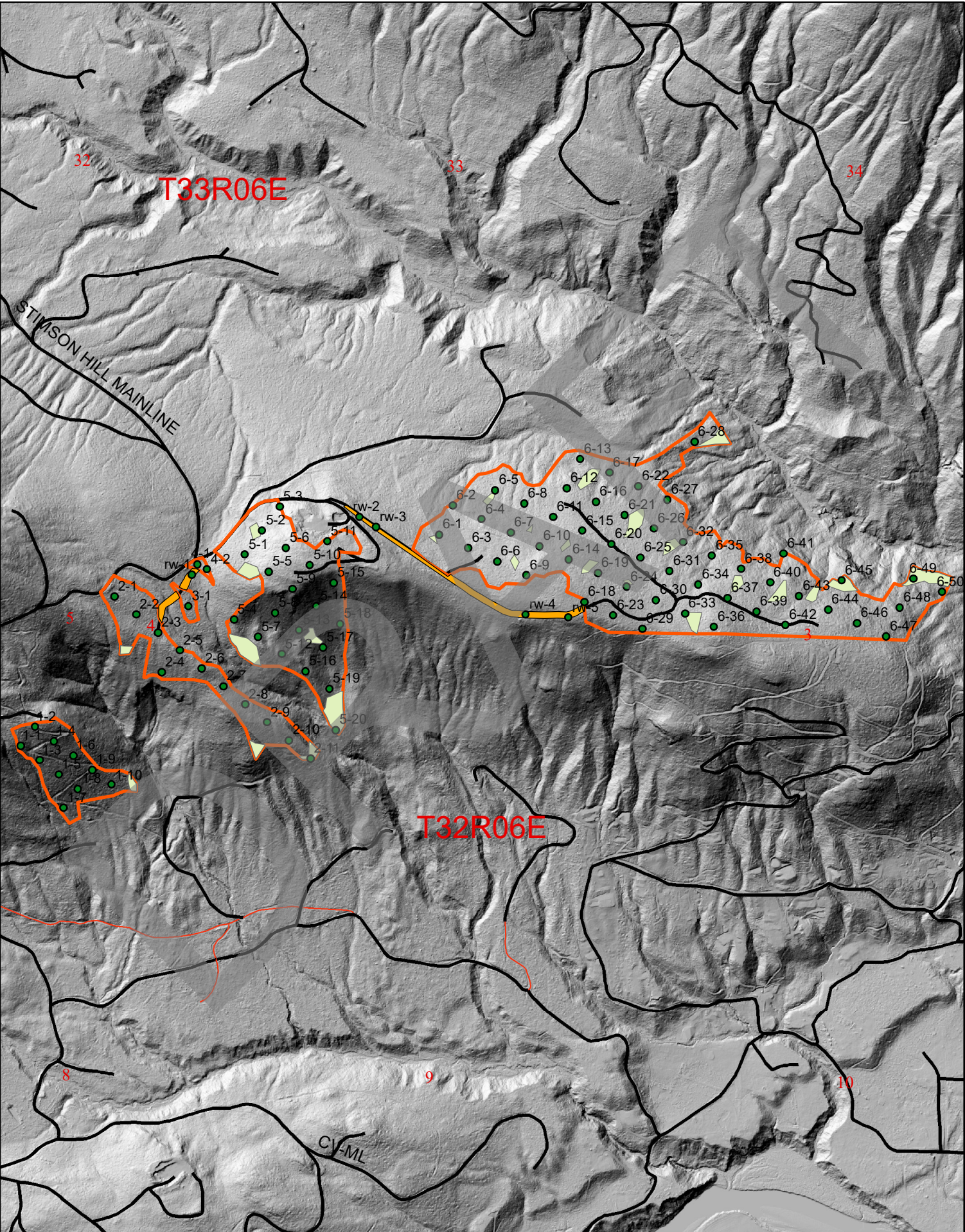



# ROAD PLAN AND SPECIFICATIONS

## #30-093860 STILLY REVISITED TIMBER SALE

SHEET INDEX	
PROJECT MAP.....	1
ROAD CLAUSES .....	2 - 23
TYPICAL SECTION.....	24 - 26
MATERIAL LIST.....	27 - 28
FARMS.....	29 - 30
STANDARD DETAILS.....	31 - 32
PIT PLAN.....	33

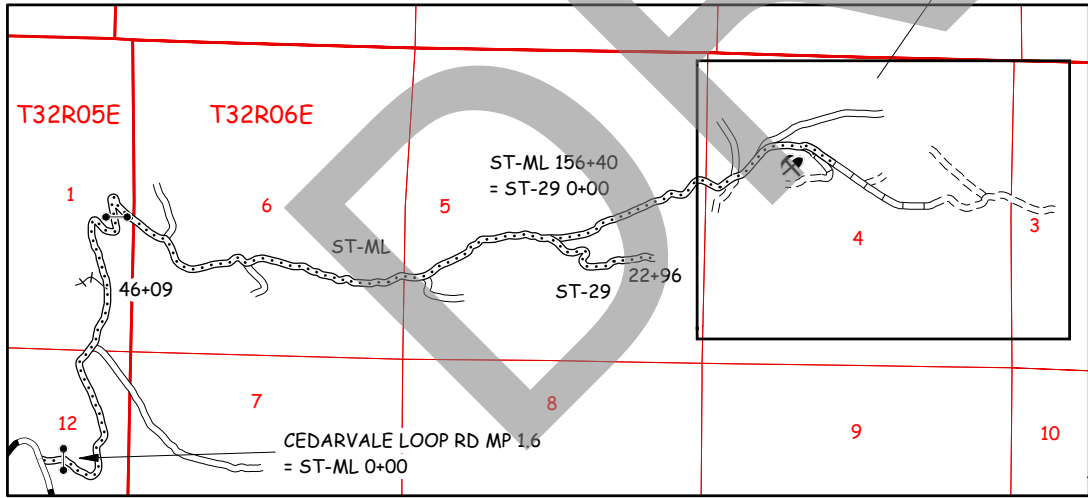
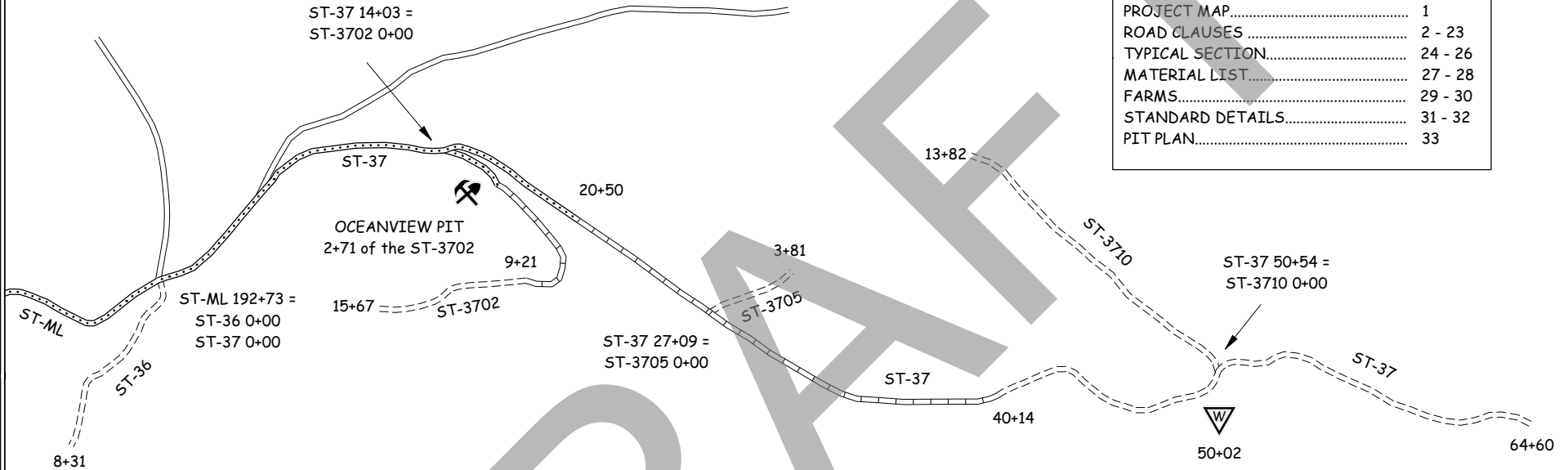

LEGEND	
PRE-HAUL MAINTENANCE	=====
REQUIRED CONSTRUCTION	-----
OPTIONAL CONSTRUCTION	- - - - -
REQUIRED RECONSTRUCTION	===== -----
OPTIONAL RECONSTRUCTION	----- - - - - -

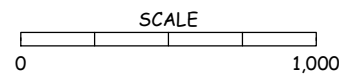

DESIGNED BY	REVIEWED BY	APPROVED BY	PLAN DATE	SHEET
J. WESTRA	ZYLSTRA 10/25/2023	ZYLSTRA 10/25/2023	8/17/2023	1 OF 33



STATE OF WASHINGTON  
DEPARTMENT OF NATURAL RESOURCES

STILLY REVISITED TIMBER SALE ROAD PLAN  
SNOHOMISH COUNTY  
CLEAR LAKE DISTRICT  
NORTHWEST REGION

AGREEMENT NO.: 30-093860

STAFF ENGINEER: J. WESTRA

DATE: AUGUST 17, 2023

SECTION 0 – SCOPE OF PROJECT

**0-1 ROAD PLAN SCOPE**

Clauses in this road plan apply to all road related work, including landings and rock source development, unless otherwise noted.

**0-2 REQUIRED ROADS**

The specified work on the following roads is required.

<u>Road</u>	<u>Stations</u>	<u>Type</u>
ST-ML	0+00 to 192+73	PREHAUL MAINTENANCE
ST-29	0+00 to 22+96	PREHAUL MAINTENANCE
ST-36	0+00 to 8+31	CONSTRUCTION
ST-37	0+00 to 20+50	PREHAUL MAINTENANCE
ST-37	20+50 to 40+14	RECONSTRUCTION
ST-37	40+14 to 64+60	CONSTRUCTION
ST-3702	0+00 to 2+71	PREHAUL MAINTENANCE
ST-3702	2+71 to 9+21	RECONSTRUCTION
ST-3702	9+21 to 15+67	CONSTRUCTION
ST-3705	0+00 to 3+81	CONSTRUCTION
ST-3710	0+00 to 13+82	CONSTRUCTION

**0-4 CONSTRUCTION**

Construction may include, but is not limited to clearing, grubbing, excavation and embankment to subgrade, drill and shoot, full-bench end-haul, landing and turnout construction, culvert installation and application of 3-inch-minus ballast.

**0-5 RECONSTRUCTION**

Reconstruction includes, but is not limited to clearing, grubbing, landing and turnout construction, culvert installation and application of 3-inch-minus ballast.

**0-6 PRE-HAUL MAINTENANCE**

This project includes, but is not limited to the following pre-haul maintenance requirements:

<u>Road</u>	<u>Stations</u>	<u>Requirements</u>
ST-ML	0+00 to 46+09	GRADE, APPLICATION OF 3" OF 2-INCH MINUS SURFACING
ST-ML	46+09 to 192+73	GRADE
ST-29	0+00 to 22+96	GRADE, APPLICATION OF 3" OF 2-INCH MINUS SURFACING
ST-37	0+00 to 14+03	GRADE
ST-37	14+03 to 20+50	GRADE, APPLICATION OF 3" OF 2-INCH MINUS SURFACING
ST-3702	0+00 to 2+71	GRADE

Additionally, Purchaser shall brush all haul roads if necessary and directed by Contract Administrator.

**0-7 POST-HAUL MAINTENANCE**

This project includes post-haul road maintenance listed in Clause 9-5 POST-HAUL MAINTENANCE.

**0-12 DEVELOP ROCK SOURCE**

Purchaser may develop an existing rock source. Rock source development will involve drilling, shooting and processing rock. Work for developing rock sources is listed in Section 6 ROCK AND SURFACING.

**SECTION 1 – GENERAL**

**1-1 ROAD PLAN CHANGES**

If the Purchaser desires a change from this road plan including, but not limited to, relocation, extension, change in design, or adding roads; a revised road plan must be submitted in writing to the Contract Administrator for consideration. Before work begins, Purchaser shall obtain approval from the State for the submitted plan.

**1-2 UNFORESEEN CONDITIONS**

Quantities established in this road plan are minimum acceptable values. Additional quantities required by the state due to unforeseen conditions, or Purchaser's choice of construction season or techniques will be at the Purchaser's expense. Unforeseen conditions include, but are not limited to, solid subsurface rock, subsurface springs, saturated ground, and unstable soils.

**1-3 ROAD DIMENSIONS**

Purchaser shall perform road work in accordance with the dimensions shown on the TYPICAL SECTION SHEET and the specifications within this road plan.

**1-4 ROAD TOLERANCES**

Purchaser shall perform road work within the tolerances listed below. The tolerance class for each road is listed on the TYPICAL SECTION SHEET.

<u>Tolerance Class</u>	<u>A</u>	<u>B</u>	<u>C</u>
Road and Subgrade Width (feet)	+1.5	+1.5	+2.0
Subgrade Elevation (feet +/-)	0.5	1.0	2.0
Centerline alignment (feet lt./rt.)	1.0	1.5	3.0

**1-6 ORDER OF PRECEDENCE**

Any conflict or inconsistency in the road plan will be resolved by giving the documents precedence in the following order:

1. Addenda.
2. Road Plan Clauses.
3. Typical Section Sheet.
4. Standard Lists.
5. Standard Details.

In case of any ambiguity or dispute over interpreting the road plan, the Contract Administrator's or designee's decision will be final.

**1-8 REPAIR OR REPLACEMENT OF DAMAGED MATERIALS**

Purchaser shall repair or replace all materials, roadway infrastructure, and road components damaged during road work or operation activities. The Contract Administrator will direct repairs and replacements. Repairs to structural materials must be made in accordance with the manufacturer's recommendation.

**1-9 DAMAGED METALLIC COATING**

Any cut ends, or damaged galvanized or aluminized coating on existing or new bridge components, culverts, downspouts, and flumes must be cleaned and treated with a minimum of two coats of zinc rich paint or cold galvanizing compound.

**1-15 ROAD MARKING**

Purchaser shall perform road work in accordance with the state’s marked location. All road work is marked as follows:

- Orange flagging and/or stakes for road centerline
- 

**1-18 REFERENCE POINT DAMAGE**

Purchaser shall reset reference points (RPs) that were moved or damaged at any time during construction to their original locations. Excavation and embankment may not proceed on road segments controlled by said RPs until Purchaser resets all moved or damaged RPs.

**1-21 HAUL APPROVAL**

Purchaser shall not use roads under this road plan for any hauling other than timber cut on the right-of-way, without written approval from the Contract Administrator.

**1-22 WORK NOTIFICATIONS**

Purchaser shall notify the Contract Administrator a minimum of 3 business days before work begins.

**1-23 ROAD WORK PHASE APPROVAL**

Purchaser shall obtain written approval from the Contract Administrator upon completion of each of the following phases of road work:

- Subgrade construction and compaction
- Drainage installation
- Rock application and compaction

**1-25 ACTIVITY TIMING RESTRICTION**

The specified activities are not allowed during the listed closure period unless authorized in writing by the Contract Administrator.

<u>Road</u>	<u>Activity</u>	<u>Closure Period</u>
ALL ROADS	ALL ACTIVITIES	November 1 to March 31

**1-26 OPERATING DURING CLOSURE PERIOD**

If permission is granted to operate during a closure period listed in Clause 1-25 ACTIVITY TIMING RESTRICTION, Purchaser shall provide a maintenance plan to include further protection of state resources. Purchaser shall obtain written approval from the Contract Administrator for the maintenance plan, and shall put preventative measures in place before operating during the closure period. Purchaser is required to maintain all haul roads at their own expense including those listed in Contract Clause C-060 DESIGNATED ROAD MAINTAINER. If other operators are using, or desire to use these designated maintainer roads, a joint operating plan must be developed. All parties shall follow this plan.

Purchaser's maintenance plan must include a total volume of rock that will be provided at the Purchaser's expense in addition to what is specified in this road plan. This rock shall be available before permission is granted to operate during the closure period and will be used as necessary along the haul route. The Contract Administrator may direct the Purchaser where to apply this maintenance rock.

**1-29 SEDIMENT RESTRICTION**

Purchaser shall not allow silt-bearing runoff to enter any streams.

**1-30 CLOSURE TO PREVENT DAMAGE**

In accordance with Contract Clause G-220 STATE SUSPENDS OPERATION, the Contract Administrator will suspend road work or hauling right-of-way timber, forest products, or rock under the following conditions:

- Wheel track rutting exceeds 4 inches on crushed rock roads.
- Surface or base stability problems persist.
- Weather is such that satisfactory results cannot be obtained in an area of operations.
- When, in the opinion of the Contract Administrator excessive road damage or rutting may occur.

Operations must stop unless authority to continue working or hauling is granted in writing by the Contract Administrator. In the event that surface or base stability problems persist, Purchaser shall cease operations, or perform corrective maintenance or repairs, subject to specifications within this road plan.

**1-33 SNOW PLOWING RESTRICTION**

Snowplowing will be allowed after the execution of a SNOW PLOWING AGREEMENT, which is available from the Contact Administrator upon request. If damage occurs while plowing, further permission to plow may be revoked by the Contract Administrator.

**1-40 ROAD APPROACHES TO COUNTY ROADS AND STATE HIGHWAYS**

Purchaser shall immediately remove any mud, dirt, rock, or other material tracked or spilled on to county roads and state highways.

If additional damage to the surface, signs, guardrails, etc. occurs then the damage will be repaired, at the Purchaser’s expense, as directed by the Contract Administrator when authorized by the county or WSDOT.

**1-43 ROAD WORK AROUND UTILITIES**

Road work is in close proximity to a utility. Known utilities are listed, but it is the Purchaser’s responsibility to identify any utilities not listed. Purchaser shall work in accordance with all applicable laws or rules concerning utilities. Purchaser is responsible for all notification, including “call before you dig”, and liabilities associated with the utilities and their rights-of-way.

<u>Road</u>	<u>Stations</u>	<u>Utility</u>	<u>Utility Contact</u>
ST-ML	0+00 to 46+09	SNOHOMISH PUD: BURIED POWER	425-783-1000

**SECTION 2 – MAINTENANCE**

**2-1 GENERAL ROAD MAINTENANCE**

Purchaser shall maintain all roads used under this contract in accordance with the FOREST ACCESS ROAD MAINTENANCE SPECIFICATIONS for the entire term of this contract. Maintenance is required even during periods of inactivity.

**2-2 ROAD MAINTENANCE – PURCHASER MAINTENANCE**

Purchaser shall perform maintenance on roads listed in Contract Clause C-050 PURCHASER ROAD MAINTENANCE AND REPAIR in accordance with FOREST ACCESS ROAD MAINTENANCE SPECIFICATIONS.

**2-3 ROAD MAINTENANCE – DESIGNATED MAINTAINER**

Purchaser may be required to perform maintenance on roads listed in Contract Clause C-060 DESIGNATED ROAD MAINTAINER as directed by the Contract Administrator. Purchaser shall maintain roads in accordance with FOREST ACCESS ROAD MAINTENANCE SPECIFICATIONS.

**2-4 PASSAGE OF LIGHT VEHICLES**

Purchaser shall maintain all roads in a condition that will allow the passage of light administrative vehicles.

**2-5 MAINTENANCE GRADING – EXISTING ROAD**

On haul roads, Purchaser shall use a grader to shape the existing surface before timber haul.

## SECTION 3 – CLEARING, GRUBBING, AND DISPOSAL

### 3-1 BRUSHING

As needed or directed by Contract Administrator on Prehaul Maintenance roads, Purchaser shall cut vegetative material up to 6 inches in diameter, including limbs, as shown on the BRUSHING DETAIL. Brushing must be achieved by mechanical cutting of brush, trees, and branches. Root systems and stumps of cut vegetation may not be disturbed unless directed by the Contract Administrator. Purchaser shall remove brushing debris from the road surface, ditchlines, and culvert inlets and outlets.

### 3-5 CLEARING

Purchaser shall fall all vegetative material larger than 2 inches DBH or over 5 feet high between the marked right-of-way boundaries and within waste and debris areas, or if not marked in the field, between the clearing limits specified on the TYPICAL SECTION SHEET. Clearing must be completed before starting excavation and embankment.

### 3-8 PROHIBITED DECKING AREAS

Purchaser shall not deck right-of-way timber in the following areas:

- Within the grubbing limits.
- Within 50 feet of any stream.
- In locations that interfere with the construction of the road prism.
- In locations that impede drainage.
- On slopes greater than 50%.
- Against standing trees.

### 3-10 GRUBBING

Purchaser shall remove all stumps between the grubbing limits specified on the TYPICAL SECTION SHEET. Purchaser shall also remove stumps with undercut roots outside the grubbing limits. Grubbing must be completed before starting excavation and embankment.

### 3-20 ORGANIC DEBRIS DEFINITION

Organic debris is defined as all vegetative material not eligible for removal by Contract Clause G-010 PRODUCTS SOLD AND SALE AREA or G-011 RIGHT TO REMOVE FOREST PRODUCTS AND CONTRACT AREA, that is larger than one cubic foot in volume within the clearing limits as shown on the TYPICAL SECTION SHEET and BRUSHING DETAIL.

### 3-21 DISPOSAL COMPLETION

Purchaser shall remove organic debris from the road surface, ditchlines, and culvert inlets and outlets. Purchaser shall complete all disposal of organic debris before the application of rock.

**3-22 DESIGNATED WASTE AREA FOR ORGANIC DEBRIS**

Waste areas for organic debris are located within the cleared right-of-way or in natural openings as designated or at areas approved by the Contract Administrator.

**3-23 PROHIBITED DISPOSAL AREAS**

Purchaser shall not place organic debris in the following areas:

- Within 50 feet of a cross drain culvert.
- Within 100 feet of a live stream, or wetland
- On road subgrades, or excavation and embankment slopes.
- On slopes greater than 50%.
- Within the operational area for cable landings where debris may shift or roll.
- On locations where brush can fall into the ditch or onto the road surface.
- Against standing timber.

**3-24 BURYING ORGANIC DEBRIS RESTRICTED**

Purchaser shall not bury organic debris unless otherwise stated in this plan.

**3-25 SCATTERING ORGANIC DEBRIS**

Purchaser shall scatter organic debris outside of the clearing limits in natural openings unless otherwise detailed in this road plan.

**3-32 END HAULING ORGANIC DEBRIS**

On the following road, and on slopes greater than 45%, Purchaser shall end haul or push organic debris to the designated waste areas specified in Clause 3-22 DESIGNATED WASTE AREA FOR ORGANIC DEBRIS.

<u>Road</u>	<u>Stations</u>
ST-37	52+63 to 56+97



## SECTION 4 – EXCAVATION

### 4-2 PIONEERING

Pioneering may not extend past construction that will be completed during the current construction season. Pioneering may not extend more than 500 feet beyond completed construction unless approved in writing by the Contract Administrator. In addition, the following actions must be taken as pioneering progresses:

- Drainage must be provided on all uncompleted construction.
- Road pioneering operations may not undercut the final cut slope or restrict drainage.
- Culverts at live stream crossings must be installed during pioneering operations prior to embankment.

### 4-3 ROAD GRADE AND ALIGNMENT STANDARDS

Purchaser shall follow these standards for road grade and alignment:

- Grade and alignment must have smooth continuity, without abrupt changes in direction.
- Maximum grades may not exceed 18 percent favorable and 15 percent adverse.
- Minimum curve radius is 60 feet at centerline.
- Maximum grade change for sag vertical curves is 5% in 100 feet.
- Maximum grade change for crest vertical curves is 4% in 100 feet.

### 4-4 SWITCHBACK STANDARDS

A switchback is defined as a curved segment of road between a beginning and end of the same curve, where the change of traffic travel direction is greater than 90 degrees.

Purchaser shall follow these standards for switchbacks:

- Maximum adverse grades for switchbacks is 10%.
- Maximum favorable grades for switchbacks is 12%.
- Maximum transition grades entering and leaving switchbacks is a 5% grade change.
- Transition grades required to meet switchback grade limitations must be constructed on the tangents preceding and departing from the switchbacks.

### 4-5 CUT SLOPE RATIO

Purchaser shall construct excavation slopes no steeper than shown on the following table:

<u>Material Type</u>	<u>Excavation Slope Ratio</u>	<u>Excavation Slope Percent</u>
Common Earth (on side slopes up to 55%)	1:1	100
Common Earth (on side slopes 56-70%)	¾:1	150
Fractured or loose rock	½:1	200
Hardpan or solid rock	¼:1	400

**4-6 EMBANKMENT SLOPE RATIO**

Purchaser shall construct embankment slopes no steeper than shown on the following table:

<u>Material Type</u>	<u>Embankment Slope Ratio</u>	<u>Embankment Slope Percent</u>
Sandy Soils	2:1	50
Common Earth and Rounded Gravel	1½:1	67
Angular Rock	1¼:1	80

**4-7 SHAPING CUT AND FILL SLOPE**

Purchaser shall construct excavation and embankment slopes to a uniform line and left rough for easier revegetation.

**4-8 CURVE WIDENING**

The minimum widening placed on the inside of curves is:

- 6 feet for curves of 50 to 79 feet radius.
- 4 feet for curves of 80 to 100 feet radius.

**4-9 EMBANKMENT WIDENING**

The minimum embankment widening is:

- 2 feet for embankment heights at centerline of 2 to 6 feet.
- 4 feet for embankment heights at centerline of greater than 6 feet.

Purchaser shall apply embankment widening equally to both sides of the road to achieve the required width.

**4-12 FULL BENCH CONSTRUCTION**

On the following road and where side slopes exceed 45%, Purchaser shall use full bench construction for the entire subgrade width. Purchaser shall end haul waste material to the location specified in Clause 4-37 WASTE AREA LOCATION.

<u>Road</u>	<u>Full Bench Location</u>
ST-37	52+63 to 56+97

**4-21 TURNOUTS**

Purchaser shall construct turnouts intervisible with a maximum distance of 1,000 feet between turnouts unless otherwise shown on drawings. Locations may be adjusted to fit the final subgrade alignment and sight distances. Locations are subject to written approval by the Contract Administrator. Minimum dimensions are shown on the TYPICAL SECTION SHEET.

**4-22 TURNAROUNDS**

Purchaser shall construct turnarounds in accordance with the TURNAROUND DETAIL on all roads. Turnarounds must be no larger than 30 feet long and 30 feet wide. Locations are subject to written approval by the Contract Administrator.

**4-25 DITCH CONSTRUCTION AND RECONSTRUCTION**

Purchaser shall construct or reconstruct ditches into the subgrade as specified on the TYPICAL SECTION SHEET. Ditches must be constructed concurrently with construction of the subgrade.

**4-27 DITCH WORK – MATERIAL USE PROHIBITED**

Purchaser shall not pull ditch material across the road or mix in with the road surface. Excavated material must be end hauled to the location specified in Clauses 4-36 through 4-38.

**4-28 DITCH DRAINAGE**

Ditches must drain to cross-drain culverts or ditchouts.

**4-29 DITCHOUTS**

Purchaser shall construct ditchouts as identified on the MATERIALS LIST and as needed and as directed by the Contract Administrator. Ditchouts must be constructed in a manner that diverts ditch water onto the forest floor and must have excavation backslopes no steeper than a 1:1 ratio.

**4-35 WASTE MATERIAL DEFINITION**

Waste material is defined as all dirt, rock, mud, or related material that is extraneous or unsuitable for construction material. Waste material, as used in Section 4 EXCAVATION, is not organic debris.

**4-36 DISPOSAL OF WASTE MATERIAL**

Purchaser may sidecast waste material on side slopes up to 55% if the waste material is compacted and free of organic debris. On side slopes greater than 55%, all waste material must be end hauled or pushed to the designated embankment sites identified by the Contract administrator.

**4-37 WASTE AREA LOCATION**

Purchaser shall deposit waste material in the listed designated areas. Additional waste areas may also be identified or approved by the Contract Administrator. The amount of material allowed in a waste area is at the discretion of the Contract Administrator.

<u>Road</u>	<u>Waste Area Location</u>	<u>Comments</u>
ST-37	50+02	Place waste on east side of road. Spread grass seed on all exposed soils.

#### **4-38 PROHIBITED WASTE DISPOSAL AREAS**

Purchaser shall not deposit waste material in the following areas:

- Within 50 feet of a cross drain culvert.
- Within 100 feet of a live stream or wetland.
- In locations that interfere with the construction of the road prism.
- In locations that impede drainage.
- Against standing timber.
- Outside the clearing limits.

#### **4-55 ROAD SHAPING**

Purchaser shall shape the subgrade and surface as shown on the TYPICAL SECTION SHEET. The subgrade and surface shape must ensure runoff in an even, un-concentrated manner, and must be uniform, firm, and rut-free.

#### **4-60 FILL COMPACTION**

Purchaser shall compact all embankment and waste material by routing equipment over the entire width of each lift.

#### **4-61 SUBGRADE COMPACTION**

Purchaser shall compact constructed and reconstructed subgrades by routing equipment over the entire width.

SECTION 5 – DRAINAGE

**5-5 CULVERTS**

Purchaser shall install culverts as part of this contract. Culverts must be installed concurrently with subgrade work and must be installed before subgrade compaction and rock application. Culvert locations and the minimum requirements for culvert length and diameter are designated on MATERIALS LIST. Culvert, downspout, and flume lengths may be adjusted to fit as-built conditions and may not terminate directly on unprotected soil. Culverts must be new material and must meet the specifications in Clauses 10-15 through 10-24.

**5-12 UNUSED MATERIALS STATE PROPERTY**

On required roads, any materials listed on the MATERIALS LIST that are not installed will become the property of the state. Purchaser shall stockpile materials as directed by the Contract Administrator.

**5-13 CONTINGENCY CULVERTS**

The following culverts will be supplied by the Purchaser and are available for installation as directed by the Contract Administrator.

<u>Road</u>	<u>Size</u>
Reconstruction or new construction roads.	One: 18" x 30' culvert

**5-15 CULVERT INSTALLATION**

Culvert installation must be in accordance with the CULVERT AND DRAINAGE SPECIFICATION DETAIL and the National Corrugated Metal Pipe Association's "Installation Manual for Corrugated Steel Drainage Structures" and the Corrugated Polyethylene Pipe Association's "Recommended Installation Practices for Corrugated Polyethylene Pipe and Fittings".

**5-16 APPROVAL FOR LARGER CULVERT INSTALLATION**

Purchaser shall obtain written approval from the Contract Administrator for the installation of culverts 36 inches in diameter and over before backfilling.

**5-17 CROSS DRAIN SKEW AND SLOPE**

Cross drains, on road grades in excess of 3%, must be skewed at least 30 degrees from perpendicular to the road centerline, except where the cross drain is at the low point in the road culverts will not be skewed. Cross drain culverts must be installed at a slope steeper than the incoming ditch grade, but not less than 3% or more than 10%.

**5-18 CULVERT DEPTH OF COVER**

Cross drain culverts must be installed with a depth of cover of not less than 1 foot of compacted subgrade over the top of the culvert at the shallowest point. Stream crossing culverts must be installed with a depth of cover recommended by the culvert manufacturer for the type and size of the pipe.

**5-20 ENERGY DISSIPATERS**

Purchaser shall install energy dissipaters in accordance with the CULVERT AND DRAINAGE SPECIFICATION DETAIL. Energy dissipater installation is subject to approval by the Contract Administrator.

The type of energy dissipater and the amount of material must be consistent with the specifications listed on the CULVERT AND DRAINAGE SPECIFICATION DETAIL.

**5-25 CATCH BASINS**

Purchaser shall construct catch basins in accordance with CULVERT AND DRAINAGE SPECIFICATION DETAIL. Minimum dimensions of catch basins are 2 feet wide and 4 feet long.

**5-26 HEADWALLS FOR CROSS DRAIN CULVERTS**

Purchaser shall construct headwalls in accordance with the CULVERT AND DRAINAGE SPECIFICATION DETAIL at all cross drain culverts. Rock used for headwalls must weigh at least 50 pounds. Rock must be placed on shoulders, slopes, and around culvert inlets and outlets. Rock may not restrict the flow of water into culvert inlets or catch basins. No placement by end dumping or dropping of rock is allowed.

**5-27 ARMORING FOR STREAM CROSSING CULVERTS**

At stream crossing culverts, Purchaser shall place riprap in conjunction with construction of the embankment. Rock must be placed on shoulders, slopes, and around culvert inlets and outlets as designated on the MATERIALS LIST or as directed by the Contract Administrator. Rock may not restrict the flow of water into culvert inlets or catch basins. Placement must be by zero-drop-height method only. No placement by end dumping or dropping of rock is allowed.

SECTION 6 – ROCK AND SURFACING

**6-2 ROCK SOURCE ON STATE LAND**

Rock used in accordance with the quantities on the TYPICAL SECTION and MATERIALS LIST may be obtained from the following source on state land at no charge to the Purchaser. Purchaser shall obtain written approval from the Contract Administrator for the use of material from any other source. If other operators are using, or desire to use the rock source, a joint operating plan must be developed. All parties shall follow this plan.

<u>Source</u>	<u>Location</u>	<u>Rock Type</u>
OCEANVIEW PIT	2+71 of the ST-3702	3-INCH MINUS BALLAST RIPRAP

**6-3 ROCK SOURCE STATE LAND, EXISTING STOCKPILE**

Rock used in accordance with the quantities on the TYPICAL SECTION and MATERIALS LIST may be obtained from the following existing stockpiles on state land at no charge to the Purchaser. Purchaser shall not remove additional yardage without prior written approval from the Contract Administrator.

<u>Source</u>	<u>Rock Type</u>	<u>Quantity</u>
OCEANVIEW PIT	2-INCH MINUS SURFACING	2,070 Cubic Yds.

**6-5 ROCK FROM COMMERCIAL SOURCE**

Rock used in accordance with the quantities on the TYPICAL SECTION and MATERIALS LIST may be obtained from any commercial source at the Purchaser's expense.

**6-10 ROCK SOURCE DEVELOPMENT PLAN BY STATE**

Purchaser shall conduct rock source development and use at the following sources, in accordance with the written ROCK SOURCE DEVELOPMENT PLAN prepared by the state and included in this road plan. Upon completion of operations, the rock source must be left in the condition specified in the ROCK SOURCE DEVELOPMENT PLAN, and approved in writing by the Contract Administrator.

<u>Source</u>	<u>Rock Type</u>
OCEANVIEW PIT	2-INCH MINUS SURFACING 3-INCH MINUS BALLAST RIPRAP

## 6-12 ROCK SOURCE SPECIFICATIONS

Rock sources must be in accordance with the following specifications:

- Pit walls may not be undermined or over steepened. The maximum slope of the walls must be consistent with recognized engineering standards for the type of material being excavated in accordance with the following table:

Material	Maximum Slope Ratio (Horiz. :Vert.)	Maximum Slope Percent
Sand	2:1	50
Gravel	1.5:1	67
Common Earth	1:1	100
Fractured Rock	0.5:1	200
Solid Rock	0:1	vertical

- Pit walls must be maintained in a condition to minimize the possibility of the walls sliding or failing.
- The width of pit benches must be a minimum of 1.5 times the maximum length of the largest machine used.
- The surface of pit floors and benches must be uniform and free-draining at a minimum 2% outslope gradient.
- All operations must be carried out in compliance with all regulations of the Regulations and Standards Applicable to Metal and Nonmetal Mining and Milling Operations (30 CFR) U.S. Department of Labor, Mine Safety and Health Administration and Safety Standards for Construction Work (296-155 WAC), Washington Department of Labor and Industries.
- All vehicle access to the top of the pit faces must be blocked.

## 6-14 DRILL AND SHOOT

Rock drilling and shooting must meet the following specifications:

- Oversize material remaining in the rock source at the conclusion of the timber sale may not exceed 5% of the total volume mined in that source.
- Oversize material is defined as rock fragments too large to be converted by the Purchaser to a size that will meet specifications used for the roads in this sale.
- All operations must be carried out in compliance with the Regulations and Standards Applicable to Metal and Nonmetal Mining and Milling Operations (30 CFR) U.S. Department of Labor, Mine Safety and Health Administration and the Safety Standards for Construction Work (296-155 WAC), Washington Department of Labor and Industries.
- Purchaser shall block access roads before blasting operations.



**6-23 ROCK GRADATION TYPES**

Purchaser shall provide rock in accordance with the types and amounts listed in the TYPICAL SECTION and MATERIALS LIST. Rock must meet the following specifications for gradation and uniform quality when placed in hauling vehicles or during manufacture and placement into a stockpile. The exact point of evaluation

**6-34 3-INCH MINUS BALLAST ROCK**

Ballast rock must be 100% equal to, or smaller than, 3 inches in at least one dimension.

Rock may contain no more than 5 percent organic debris, dirt, and trash.

**6-50 LIGHT LOOSE RIP RAP**

Light loose rip rap must consist of angular, hard, sound, and durable stone. It must be free from segregation, seams, cracks, and other defects tending to destroy its resistance to weather. Light loose rip rap must be free of rock fines, soil, organic debris or other extraneous material, and must meet the following requirements:

<u>Quantity</u>	<u>Approximate Size Range</u>
20% to 90%	500 lbs. to 1 ton (18" - 28")
15% to 80%	50 lbs. to 500 lbs. (8" - 18")
10% to 20%	3 inch to 50 lbs. (3" - 8")

**6-51 HEAVY LOOSE RIP RAP**

Heavy loose rip rap must consist of angular, hard, sound, and durable stone. It must be free from segregation, seams, cracks, and other defects tending to destroy its resistance to weather. Heavy loose rip rap must be free of rock fines, soil, organic debris or other extraneous material, and must meet the following requirements:

<u>Quantity</u>	<u>Size Range</u>
30% to 90%	1 ton to 2 ton (28" - 36")
30% to 70%	500 lbs. to 1 ton (18" - 28")
20% to 50%	50 lbs. to 500 lbs. (8" - 18")
10% to 20%	3 inch to 50 lbs. (3" - 8")

**6-55 ROCK APPLICATION MEASURED BY COMPACTED DEPTH**

Measurement of specified rock depths, are defined as the compacted depths using the compaction methods required in this road plan. Estimated quantities specified in the TYPICAL SECTION are loose yards. Purchaser shall apply adequate amounts of rock to meet the specified rock depths. Specified rock depths are minimum requirements, and are not subject to reduction.

**6-70 APPROVAL BEFORE ROCK APPLICATION**

Purchaser shall obtain written approval from the Contract Administrator for culvert installation, ditch construction, ditch reconstruction, headwall construction, and headwall reconstruction before rock application.

**6-71 ROCK APPLICATION**

Purchaser shall apply rock in accordance with the specifications and quantities shown on the TYPICAL SECTION. Rock must be spread, shaped, and compacted full width concurrent with rock hauling operations. The Contract Administrator will direct locations for rock that is to be applied as spot patching. Road surfaces must be compacted in accordance with the TYPICAL SECTION by routing equipment over the entire width.

**6-72 ROCK APPLICATION AFTER HAULING**

On the following roads, upon completion of all hauling operations, Purchaser shall apply rock in accordance with the quantities shown on the ROCK LIST and listed below.

<u>Road</u>	<u>Location</u>	<u>Rock Type</u>
ST-ML	0+00 to 46+09	3" lift of 2-Inch Minus Surfacing

**6-73 ROCK FOR WIDENED PORTIONS**

Purchaser shall apply rock to turnarounds, turnouts, and areas with curve widening to the same depth and specifications as the traveled way.

**6-81 CHEMICAL TREATMENT FOR DUST ABATEMENT**

Purchaser shall treat the following roads with Lignin Sulfonate for dust abatement. No other chemical may be used for dust abatement. The Lignin Sulfonate may not be used for any other purposes.

<u>Road</u>	<u>Stations</u>
ST-ML	0+00 to 46+09

**6-82 CHEMICAL RESTRICTION**

Purchaser shall not allow chemicals used for dust abatement to enter any streams.

**6-83 LIGNIN SULFONATE APPLICATION RATE**

The "as supplied" liquid Lignin Sulfonate must be diluted with an adequate amount of water to obtain a 25% solids content for application. Purchaser shall apply Lignin Sulfonate to the surface at a rate not less than 0.5 gallons per square yard (approximately 77.8 gallons per station).

**6-85 CHEMICAL DUST ABATEMENT EQUIPMENT**

Application equipment used to spread dust abatement chemicals must be capable of uniform application. A tanker truck with a “slash pan” or “plate” is not acceptable. Field dilution must be accomplished within the application vehicle.

**6-86 TIMING FOR CHEMICAL APPLICATION**

Purchaser shall obtain prior written approval from the Contract Administrator for the timing of application for dust abatement chemicals. It is intended that dust abatement chemicals be applied during the summer season.

SECTION 8 – EROSION CONTROL

**8-2 PROTECTION FOR EXPOSED SOIL**

Purchaser shall provide and evenly spread a 3-inch layer of straw to all exposed soils at culvert installations. Soils must be covered before the first anticipated storm event. Soils may not sit exposed during any rain event.

**8-15 REVEGETATION**

Purchaser shall spread seed and fertilizer on all exposed soils within the grubbing limits resulting from road work activities. Cover all exposed soils using manual dispersal of grass seed and fertilizer. Other methods of covering must be approved in writing by the Contract Administrator.

**8-16 REVEGETATION SUPPLY**

The Purchaser shall provide the seed and fertilizer.

**8-17 REVEGETATION TIMING**

Purchaser shall revegetate during the first available opportunity after road work is completed. Soils may not be allowed to sit exposed for longer than one month without receiving revegetation treatment unless otherwise approved in writing by the Contract Administrator.

**8-18 PROTECTION FOR SEED**

Purchaser shall provide a protective cover for seed if revegetation occurs between July 1 and March 31. The protective cover may consist of dispersed straw, jute matting, or clear plastic sheets. The protective cover requirement may be waived in writing by the Contract Administrator if Purchaser is able to demonstrate a revegetation plan that will result in the establishment of a uniform dense crop (at least 50% coverage) of 3-inch tall grass by October 31.

**8-19 ASSURANCE FOR SEEDED AREA**

Purchaser shall ensure the growth of a uniform and dense crop (at least 50% coverage) of 3-inch tall grass. Purchaser shall reapply the grass seed and fertilizer in areas that have failed to germinate or have been damaged through any cause. Restore eroded or disturbed areas, clean up and properly dispose of eroded materials, and reapply the seed and fertilizer at no addition cost to the state.

**8-25 GRASS SEED**

Purchaser shall evenly spread the seed mixture listed below on all exposed soil inside the grubbing limits at a rate of 50 pounds per acre of exposed soil. Grass seed must meet the following specifications:

1. Weed seed may not exceed 0.5% by weight.
2. All seed species must have a minimum 90% germination rate, unless otherwise specified.
3. Seed must be certified.
4. Seed must be furnished in standard containers showing the following information:
  - a. Common name of seed
  - b. Net weight
  - c. Percent of purity
  - d. Percentage of germination
  - e. Percentage of weed seed and inert material
5. Seed must conform to the following mixture.

<u>Kind and Variety of Seed in Mixture</u>	<u>% by Weight</u>
Creeping Red Fescue	50
Elf Perennial Rye Grass	25
Highland Colonial Bentgrass	15
White Clover	10
Inert and Other Crop	0.5

**8-27 FERTILIZER**

Purchaser shall evenly spread the fertilizer listed below on all exposed soil inside the grubbing limits at a rate of 200 pounds per acre of exposed soil. Fertilizer must meet the following specifications:

<u>Chemical Component</u>	<u>% by Weight</u>
Nitrogen	16
Phosphorous	16
Potassium	16
Sulphur	3
Inerts	49

SECTION 9 – POST-HAUL road work

**9-3 CULVERT MATERIAL REMOVED FROM STATE LAND**

Culverts removed from roads become the property of the Purchaser and must be removed from state land.

**9-5 POST-HAUL MAINTENANCE**

Purchaser shall perform post-haul maintenance in accordance with the FOREST ACCESS ROAD MAINTENANCE SPECIFICATIONS and as specified below.

<u>Road</u>	<u>Stations</u>	<u>Additional Requirements</u>
ST-ML	0+00 to 46+09	Apply post haul rock per Clause 6-72.

**9-10 LANDING DRAINAGE**

Purchaser shall provide for drainage of the landing surface.

**9-11 LANDING EMBANKMENT**

Purchaser shall slope landing embankments to the original construction specifications.

**9-21 ROAD ABANDONMENT**

Purchaser shall abandon the following roads before the termination of this contract.

<u>Road</u>	<u>Stations</u>
ST-37	50+54 to 64+60

**9-22 ABANDONMENT**

- Remove all ditch relief culverts. The resulting slopes must be 1:1 or flatter. Place and compact the removed fill material in a location that will not erode into any Type 1 through 5 waters or wetlands.
- Remove all culverts in natural drainages. The resulting slopes must be 1.5:1 or flatter. Strive to match the existing native stream bank gradient. The natural streambed width must be re-established. Place and compact the removed fill material in a location that will not erode into any Type 1 through 5 waters or wetlands.
- Transport all removed culverts off site. All removed culverts are the property of the Purchaser.
- Construct non-drivable waterbars at natural drainage points and at a spacing that will produce a vertical drop of no more than 20 feet between waterbars and with a maximum horizontal spacing of 400 feet.
- Skew waterbars at least 30 degrees from perpendicular to the road centerline on roads in excess of 3 percent grade.
- Key waterbars into the cut-slope to intercept the ditch. Waterbars must be outsloped to provide positive drainage. Outlets must be on stable locations.

- Inslope or outslope the road as appropriate.
- Remove bridges and other structures.
- Pull back unstable fill that has potential of failing and entering any Type 1 through 5 waters or wetlands. Place and compact removed material in a stable location.
- Remove berms except as designed.
- Block the road by constructing an aggressive barrier of dense interlocked large woody debris (logs, stumps, root wads, etc.) so that four wheel highway vehicles cannot pass the point of abandonment. Typical barrier dimensions are 10 feet high by 20 feet deep, spanning the entire road prism from top of cutslope to toe of fillslope. Long term effectiveness is the primary objective. If necessary construct a vehicular turn-around near the point of abandonment.
- Apply grass seed to all exposed soils resulting from the abandonment work and in accordance with Section 8 EROSION CONTROL.

## SECTION 10 MATERIALS

### **10-15 CORRUGATED STEEL CULVERT**

Metallic coated steel culverts must meet AASHTO M-36 (ASTM A-760) specifications. Culverts must be galvanized (zinc coated meeting AASHTO M-218).

### **10-17 CORRUGATED PLASTIC CULVERT**

Polyethylene culverts must meet AASHTO M-294 specifications, or ASTM F-2648 specifications for recycled polyethylene. Culverts must be Type S – double walled with a corrugated exterior and smooth interior.

### **10-21 METAL BAND**

Metal coupling and end bands must meet the AASHTO specification designated for the culvert and must have matching corrugations. Culverts 24 inches and smaller must have bands with a minimum width of 12 inches. Culverts over 24 inches must have bands with a minimum width of 24 inches.

### **10-22 PLASTIC BAND**

Plastic coupling and end bands must meet the AASHTO specification designated for the culvert. Only fittings supplied or recommended by the culvert manufacturer may be used.

**10-24 GAUGE AND CORRUGATION**

Metal culverts must conform to the following specifications for gage and corrugation as a function of diameter.

<u>Diameter</u>	<u>Gage</u>	<u>Corrugation</u>
18"	16 (0.064")	2 2/3" X 1/2"
24" to 48"	14 (0.079")	2 2/3" X 1/2"
54" to 96"	14 (0.079")	3" X 1"

SECTION 11 SPECIAL NOTES

**11-1 LANDING CONSTRUCTION ON EXISTING ROADS**

Purchaser may construct landings at the ends or edges of existing roads as listed below. Landings must not impede road traffic, ditch flow or culvert drainage. Waste soils must be hauled to a location approved by the contract administrator.

<u>Road</u>	<u>Station</u>	<u>Comment</u>
ST-29	22+96	Landing may be constructed on downhill side of road.

ROAD #		ST-ML	ST-ML	ST-ML	ST-29
REQUIRED / OPTIONAL		REQUIRED	REQUIRED	REQUIRED	REQUIRED
CONSTRUCT / RECONSTRUCT		PRE-HAUL	POST-HAUL	PRE-HAUL	PRE-HAUL
TOLERANCE CLASS (A/B/C)		C	C	C	C
STATION / MP TO		0+00	0+00	46+09	0+00
STATION / MP		46+09	46+09	192+73	22+96
ROAD WIDTH	R	12	12	12	12
CROWN (INCHES @ C/L)		3	3	3	3
DITCH WIDTH	W	3	3	3	3
DITCH DEPTH	D	1	1	1	1
TURNOUT LENGTH	L	--	--	--	--
TURNOUT WIDTH	T	--	--	--	--
TURNOUT TAPER	P	--	--	--	--
GRUBBING	G1	--	--	--	--
	G2	--	--	--	--
CLEARING	C1	--	--	--	--
	C2	--	--	--	--
ROCK FILLSLOPE	K:1	1 ½ : 1	1 ½ : 1	--	1 ½ : 1
❖ BALLAST DEPTH	B1	--	--	--	--
CUBIC YARDS / STATION		--	--	--	--
➤ TOTAL CY BALLAST		--	--	--	--
❖ SURFACING DEPTH	B2	3	3	--	3
CUBIC YARDS / STATION		17	17	--	17
➤ TOTAL CY SURFACING		785 <sup>A</sup>	785 <sup>A</sup>	--	390 <sup>A</sup>
➤ TOTAL CUBIC YARDS		785	785	--	390
SUBGRADE WIDTH	S	12.5	12.5	--	12.5
BRUSHCUT (Y/N)		N	N	N	N
BLADE, SHAPE, & DITCH (Y/N)		Y	Y	Y	Y

### TYPICAL SECTION

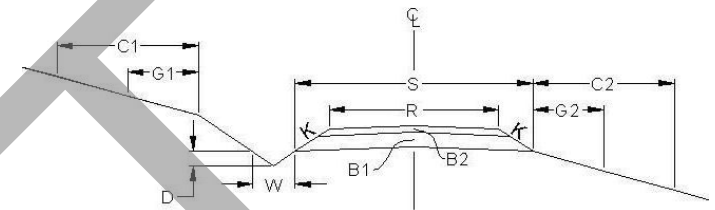

### TURNOUT DETAIL (PLAN VIEW)

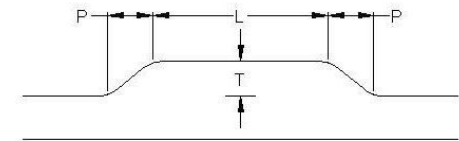

### SYMBOL NOTES

- ❖ Specified Rock Depth is FINISHED COMPACTED DEPTH in inches.
- Specified Rock Quantity is LOOSE MEASURE (Truck Cubic Yards) needed to accomplish specified FINISHED COMPACTED DEPTH. Rock quantities include volume for turnouts, curve widening and landings.

### Rock Totals Summary

Type	Quantity (Cubic Yards)
A: 2-Inch Minus Surfacing	2,070
B: 3-Inch Minus Ballast	7,990
Rip Rap	180



ROAD #		ST-36	ST-37	ST-37	ST-37	ST-37	ST-3702	ST-3702	ST-3702
REQUIRED / OPTIONAL		REQUIRED	REQUIRED	REQUIRED	REQUIRED	REQUIRED	REQUIRED	REQUIRED	REQUIRED
CONSTRUCT / RECONSTRUCT		CONSTRUCT	PRE-HAUL	PRE-HAUL	RECONSTRUCT	CONSTRUCT	PRE-HAUL	RECONSTRUCT	CONSTRUCT
TOLERANCE CLASS (A/B/C)		C	C	C	C	C	C	C	C
STATION / MP TO		0+00	0+00	14+03	20+50	40+14	0+00	2+71	9+21
STATION / MP		8+31	14+03	20+50	40+14	64+60	2+71	9+21	15+67
ROAD WIDTH	R	12	12	12	12	12	12	12	12
CROWN (INCHES @ C/L)		3	3	3	3	3	3	3	3
DITCH WIDTH	W	3	3	3	3	3	3	3	3
DITCH DEPTH	D	1	1	1	1	1	1	1	1
TURNOUT LENGTH	L	--	--	--	50	50	--	--	50
TURNOUT WIDTH	T	--	--	--	10	10	--	--	10
TURNOUT TAPER	P	--	--	--	25	25	--	--	25
GRUBBING	G1	5	--	--	5	5	--	--	5
	G2	5	--	--	5	5	--	--	5
CLEARING	C1	10	--	--	10	10	--	--	10
	C2	10	--	--	10	10	--	--	10
ROCK FILLSLOPE	K:1	1 ½ : 1	--	--	1 ½ : 1	1 ½ : 1	--	1 ½ : 1	1 ½ : 1
❖ BALLAST DEPTH	B1	18	--	--	9	18	--	9	18
CUBIC YARDS / STATION		114	--	--	53	114	--	53	114
➤ TOTAL CY BALLAST		945 <sup>B</sup>	--	--	1,040 <sup>B</sup>	2,790 <sup>B</sup>	--	470 <sup>B</sup>	735 <sup>B</sup>
❖ SURFACING DEPTH	B2	--	--	3	--	--	--	--	--
CUBIC YARDS / STATION		--	--	17	--	--	--	--	--
➤ TOTAL CY SURFACING		--	--	110 <sup>A</sup>	--	--	--	--	--
➤ TOTAL CUBIC YARDS		945	--	110	1,040	2,790	--	470	735
SUBGRADE WIDTH	S	16.5	12	12	14	16.5	12	14	16.5
BRUSHCUT (Y/N)		N	N	N	N	N	N	N	N
BLADE, SHAPE, & DITCH (Y/N)		N	Y	Y	N	N	Y	N	N

ROAD #		ST-3705	ST-3710						
REQUIRED / OPTIONAL		REQUIRED	REQUIRED						
CONSTRUCT / RECONSTRUCT		CONSTRUCT	CONSTRUCT						
TOLERANCE CLASS (A/B/C)		C	C						
STATION / MP TO		0+00	0+00						
STATION / MP		3+81	13+82						
ROAD WIDTH	R	12	12						
CROWN (INCHES @ C/L)		3	3						
DITCH WIDTH	W	3	3						
DITCH DEPTH	D	1	1						
TURNOUT LENGTH	L	--	50						
TURNOUT WIDTH	T	--	10						
TURNOUT TAPER	P	--	25						
GRUBBING	G1	5	5						
	G2	5	5						
CLEARING	C1	10	10						
	C2	10	10						
ROCK FILLSLOPE	K:1	1 ½ : 1	1 ½ : 1						
❖ BALLAST DEPTH	B1	18	18						
CUBIC YARDS / STATION		114	114						
➤ TOTAL CY BALLAST		435 <sup>B</sup>	1,575 <sup>B</sup>						
❖ SURFACING DEPTH	B2	--	--						
CUBIC YARDS / STATION		--	--						
➤ TOTAL CY SURFACING		--	--						
➤ TOTAL CUBIC YARDS		435	1,575						
SUBGRADE WIDTH	S	16.5	16.5						
BRUSHCUT (Y/N)		N	N						
BLADE, SHAPE, & DITCH (Y/N)		N	N						

## MATERIALS LIST

LOCATION		CULVERT			DWNSPT		RIPRAP			FILL TYPE	TOLERANCE	REMARKS											
ROAD #	STATION	DIAMETER	LENGTH	TYPE	LENGTH	TYPE	INLET	OUTLET	TYPE														
											<b>Note:</b> Galvanized metal culverts shall conform to the following specifications for gage and corrugation as a function of the diameter:												
											<table style="width: 100%; border-collapse: collapse;"> <tr> <th style="text-align: left;">Diameter</th> <th style="text-align: center;">Gage</th> <th style="text-align: center;">Corrugation</th> </tr> <tr> <td style="text-align: center;">18"</td> <td style="text-align: center;">16</td> <td style="text-align: center;">2 2/3" x 1/2"</td> </tr> <tr> <td style="text-align: center;">24" – 48"</td> <td style="text-align: center;">14</td> <td style="text-align: center;">2 2/3" x 1/2"</td> </tr> <tr> <td style="text-align: center;">54" – 96"</td> <td style="text-align: center;">14</td> <td style="text-align: center;">3" x 1"</td> </tr> </table>	Diameter	Gage	Corrugation	18"	16	2 2/3" x 1/2"	24" – 48"	14	2 2/3" x 1/2"	54" – 96"	14	3" x 1"
Diameter	Gage	Corrugation																					
18"	16	2 2/3" x 1/2"																					
24" – 48"	14	2 2/3" x 1/2"																					
54" – 96"	14	3" x 1"																					
ST-36	1+26	18	30	PD	--	--	2	3	L	NT	C												
ST-36	2+01	24	30	PD	--	--	2	3	L	NT	C	TYPE 4 STREAM											
ST-36	4+32	18	30	PD	--	--	2	3	L	NT	C												
ST-36	4+97	36	50	GM	--	--	4	6	L/H	NT	C	TYPE 4 STREAM											
ST-36	6+42	24	30	PD	--	--	2	3	L	NT	C	TYPE 5 STREAM											
ST-36	7+45	18	30	PD	--	--	2	3	L	NT	C												
ST-37	16+93	18	30	PD	--	--	2	3	L	NT	C												
ST-37	19+03	18	30	PD	--	--	2	3	L	NT	C												
ST-37	21+50	18	30	PD	--	--	2	3	L	NT	C												
ST-37	23+63	18	30	PD	--	--	2	3	L	NT	C												
ST-37	26+05	18	30	PD	--	--	2	3	L	NT	C												
ST-37	29+03	18	30	PD	--	--	2	3	L	NT	C												
ST-37	31+03	18	30	PD	--	--	2	3	L	NT	C												
ST-37	33+06	18	30	PD	--	--	2	3	L	NT	C												
ST-37	34+37	18	30	PD	--	--	2	3	L	NT	C												
ST-37	35+99	18	30	PD	--	--	2	3	L	NT	C												
ST-37	37+54	18	30	PD	--	--	2	3	L	NT	C												
ST-37	49+22	18	30	PD	--	--	2	3	L	NT	C												
ST-37	51+36	18	30	PD	--	--	2	3	L	NT	C												
ST-37	53+59	18	30	PD	--	--	2	3	L	NT	C												

GM – Galvanized Metal    PS – Polyethylene Pipe Single Wall    PD – Polyethylene Pipe Dual Wall    AM – Aluminized Metal    C – Concrete    XX – PD or GM  
H – Heavy Loose Riprap    L – Light Loose Riprap    SR – Shot Rock    NT – Native (Bank Run)    QS – Quarry Spalls

## MATERIALS LIST

LOCATION		CULVERT			DWNSPT		RIPRAP			FILL TYPE	TOLERANCE	REMARKS											
ROAD #	STATION	DIAMETER	LENGTH	TYPE	LENGTH	TYPE	INLET	OUTLET	TYPE														
<p><b>Note:</b> Galvanized metal culverts shall conform to the following specifications for gage and corrugation as a function of the diameter:</p> <table style="width: 100%; border-collapse: collapse;"> <thead> <tr> <th style="text-align: center;">Diameter</th> <th style="text-align: center;">Gage</th> <th style="text-align: center;">Corrugation</th> </tr> </thead> <tbody> <tr> <td style="text-align: center;">18"</td> <td style="text-align: center;">16</td> <td style="text-align: center;">2 2/3" x 1/2"</td> </tr> <tr> <td style="text-align: center;">24" – 48"</td> <td style="text-align: center;">14</td> <td style="text-align: center;">2 2/3" x 1/2"</td> </tr> <tr> <td style="text-align: center;">54" – 96"</td> <td style="text-align: center;">14</td> <td style="text-align: center;">3" x 1"</td> </tr> </tbody> </table>												Diameter	Gage	Corrugation	18"	16	2 2/3" x 1/2"	24" – 48"	14	2 2/3" x 1/2"	54" – 96"	14	3" x 1"
Diameter	Gage	Corrugation																					
18"	16	2 2/3" x 1/2"																					
24" – 48"	14	2 2/3" x 1/2"																					
54" – 96"	14	3" x 1"																					
ST-37	56+32	18	30	PD	--	--	2	3	L	NT	C												
ST-37	57+49	18	30	PD	--	--	2	3	L	NT	C												
ST-37	59+35	18	30	PD	--	--	2	3	L	NT	C												
ST-37	60+85	18	30	PD	--	--	2	3	L	NT	C												
ST-37	63+12	18	30	PD	--	--	2	3	L	NT	C												
ST-3702	4+98	18	30	PD	--	--	2	3	L	NT	C												
ST-3702	11+67	18	30	PD	--	--	2	3	L	NT	C												
ST-3702	12+95	18	30	PD	--	--	2	3	L	NT	C												
ST-3705	2+29	18	30	PD	--	--	2	3	L	NT	C												
ST-3710	1+87	18	30	PD	--	--	2	3	L	NT	C												
ST-3710	2+53	18	30	PD	--	--	2	3	L	NT	C												
ST-3710	5+11	18	30	PD	--	--	2	3	L	NT	C												
ST-3710	7+55	18	30	PD	--	--	2	3	L	NT	C												
ST-3710	11+10	18	30	PD	--	--	2	3	L	NT	C												
ST-3710	12+55	18	30	PD	--	--	2	3	L	NT	C												

GM – Galvanized Metal    PS – Polyethylene Pipe Single Wall    PD – Polyethylene Pipe Dual Wall    AM – Aluminized Metal    C – Concrete    XX – PD or GM  
H – Heavy Loose Riprap    L – Light Loose Riprap    SR – Shot Rock    NT – Native (Bank Run)    QS – Quarry Spalls

## FOREST ACCESS ROAD MAINTENANCE SPECIFICATIONS

### Cuts and Fills

- Maintain slope lines to a stable gradient compatible with the construction materials. Remove slides from ditches and the roadway. Repair fill-failures, in accordance with Clause 4-6 EMBANKMENT SLOPE RATIO, with selected material or material approved by the Contract Administrator. Remove overhanging material from the top of cut slopes.
- Waste material from slides or other sources shall be placed and compacted in stable locations identified in the road plan or approved by the Contract Administrator, so that sediment will not deliver to any streams or wetlands.
- Slide material and debris shall not be mixed into the road surface materials, unless approved by the Contract Administrator.

### Surface

- Grade and shape the road surface, turnouts, and shoulders to the original shape on the TYPICAL SECTION SHEET. Inslope or outslope as directed to provide a smooth, rut-free traveled surface and maintain surface water runoff in an even, unconcentrated manner.
- Blading shall not undercut the backslope or cut into geotextile fabric on the road.
- If required by the Contract Administrator, water shall be applied as necessary to control dust and retain fine surface rock.
- Surface material shall not be bladed off the roadway. Replace surface material when lost or worn away, or as directed by the Contract Administrator.
- Remove shoulder berms, created by grading, to facilitate drainage, except as marked or directed by the Contract Administrator.
- For roads with geotextile fabric: spread surface aggregate to fill in soft spots and wheel ruts (barrel spread) to prevent damage to the geotextile fabric.

### Drainage

- Prevent silt bearing road surface and ditch runoff from delivering sediment to any streams or wetlands.
- Maintain rolling dips and drivable waterbars as needed to keep them functioning as intended.
- Maintain headwalls to the road shoulder level with material that will resist erosion.
- Maintain energy dissipaters at culvert outlets with non-erodible material or rock.
- Keep ditches, culverts, and other drainage structures clear of obstructions and functioning as intended.
- Inspect and clean culverts at least monthly, with additional inspections during storms and periods of high runoff. This shall be done even during periods of inactivity.

## FOREST ACCESS ROAD MAINTENANCE SPECIFICATIONS

### Preventative Maintenance

- Perform preventative maintenance work to safeguard against storm damage, such as blading to ensure correct runoff, ditch and culvert cleaning, and waterbar maintenance.

### Termination of Use or End of Season

- At the conclusion of logging operations, ensure all conditions of these specifications have been met.

### Debris

- Remove fallen timber, limbs, and stumps from the slopes, roadway, ditchlines, and culvert inlets.

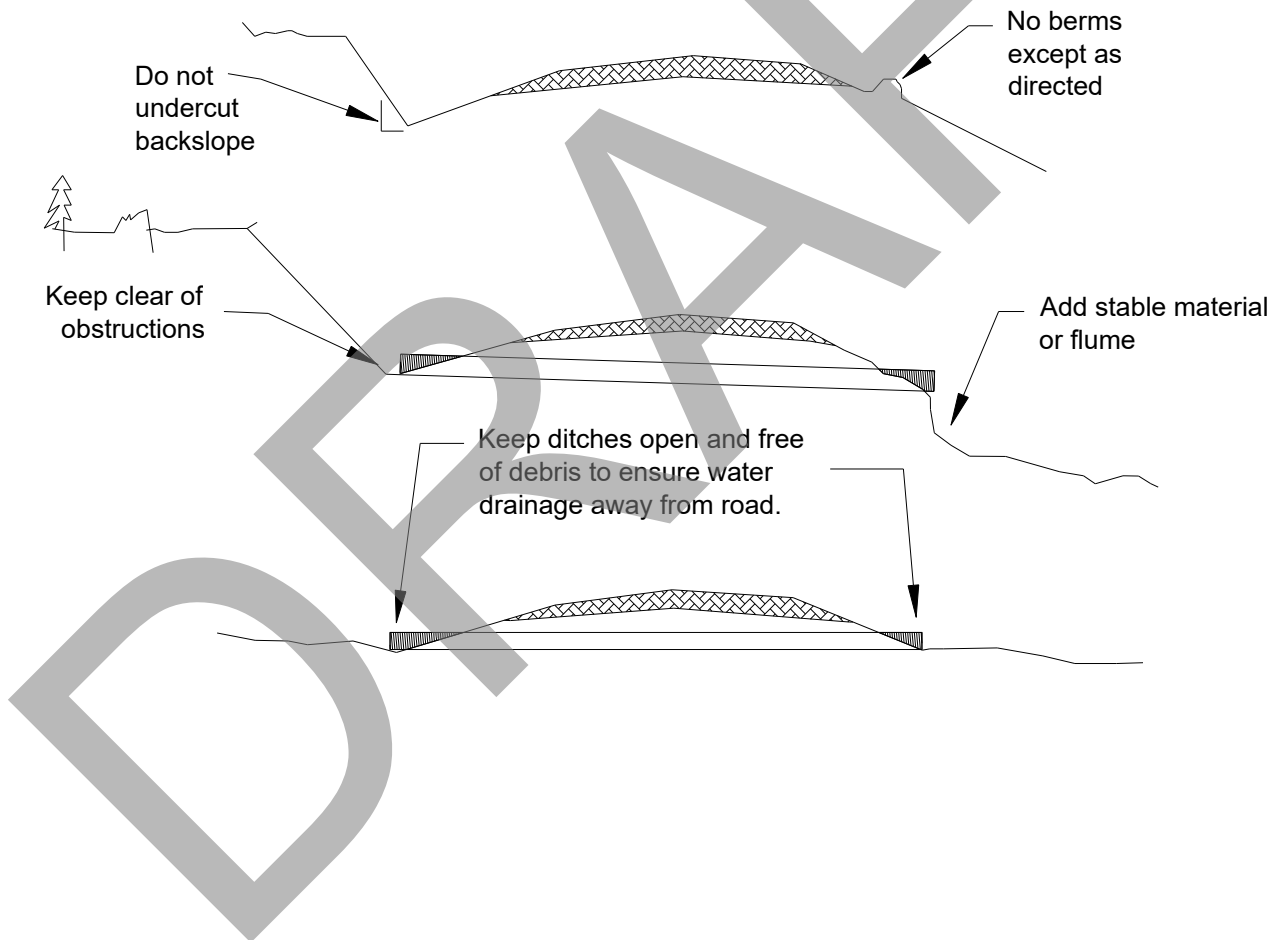

# TURNAROUND DETAILS

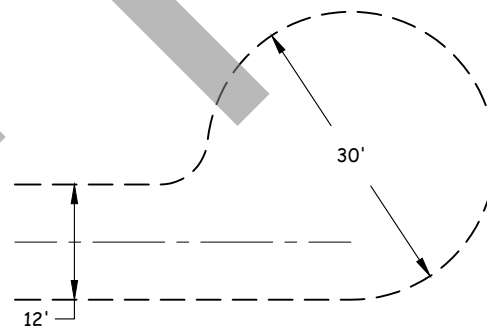
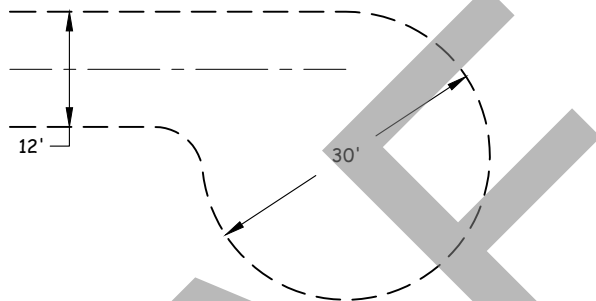
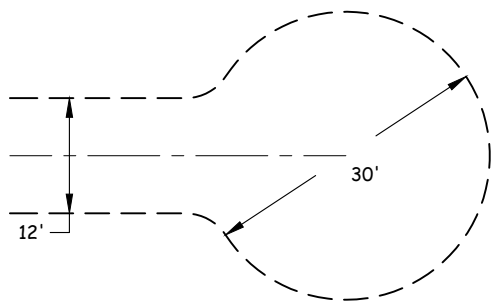

CUL-DE-SAC

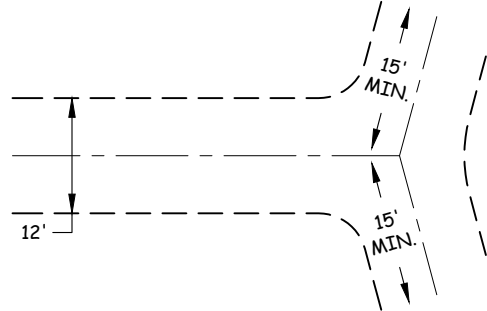
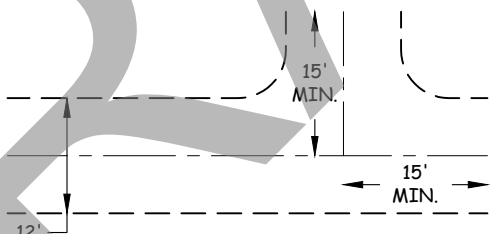
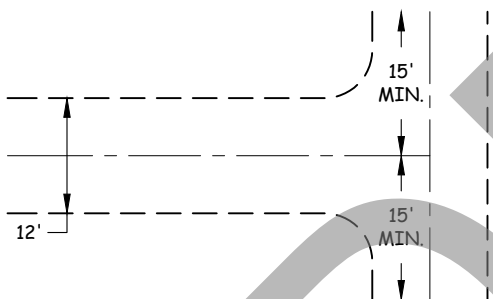

HAMMERHEAD

3-POINT SIDE

3-POINT WYE

TURNAROUND TYPE AND TURNAROUND LOCATION ARE SUBJECT TO THE APPROVAL OF THE CONTRACT ADMINISTRATOR.

ROCK SHALL BE APPLIED THROUGHOUT THE TURNAROUND TO THE SAME DEPTH AND SPECIFICATIONS AS LISTED IN THE TYPICAL SECTION.

CONTRACT # 30-093860	PROJECT STILLY REVISITED	SHEET 31 OF 32
-------------------------	-----------------------------	-------------------

# CULVERT AND DRAINAGE SPECIFICATIONS

**CULVERT INSTALLATION (TYPICAL)**

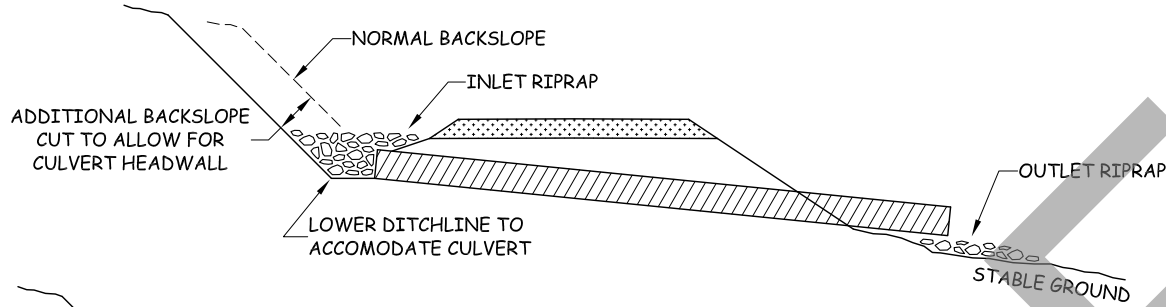

**CULVERT HEADWALL - SECTION VIEW**

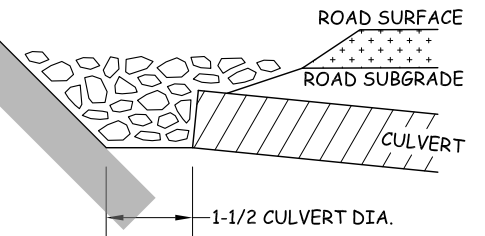

**CULVERT INSTALLATION WITH DOWNSPOUT**

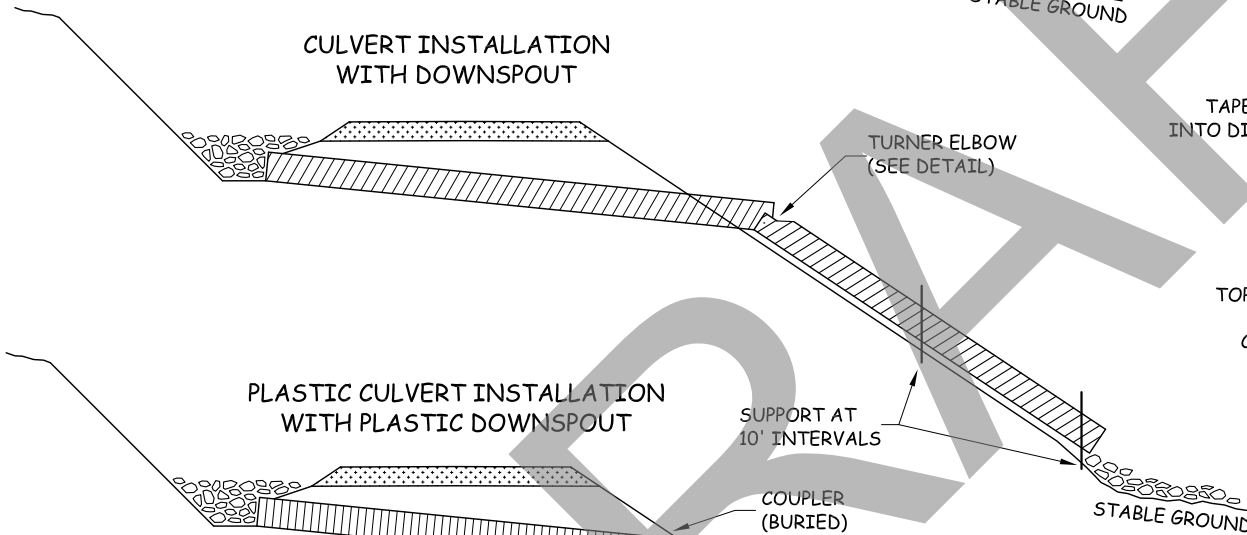

**CULVERT HEADWALL - PLAN VIEW**

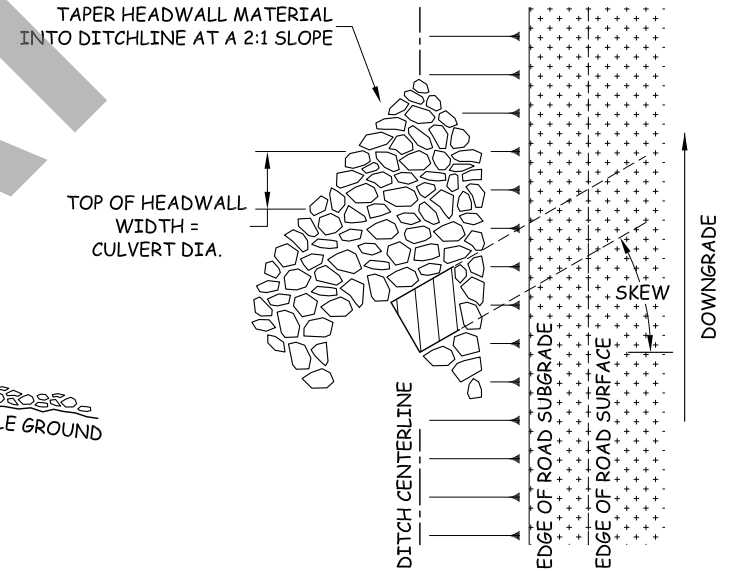

**PLASTIC CULVERT INSTALLATION WITH PLASTIC DOWNSPOUT**

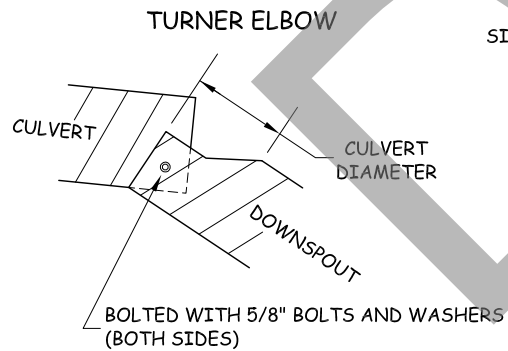
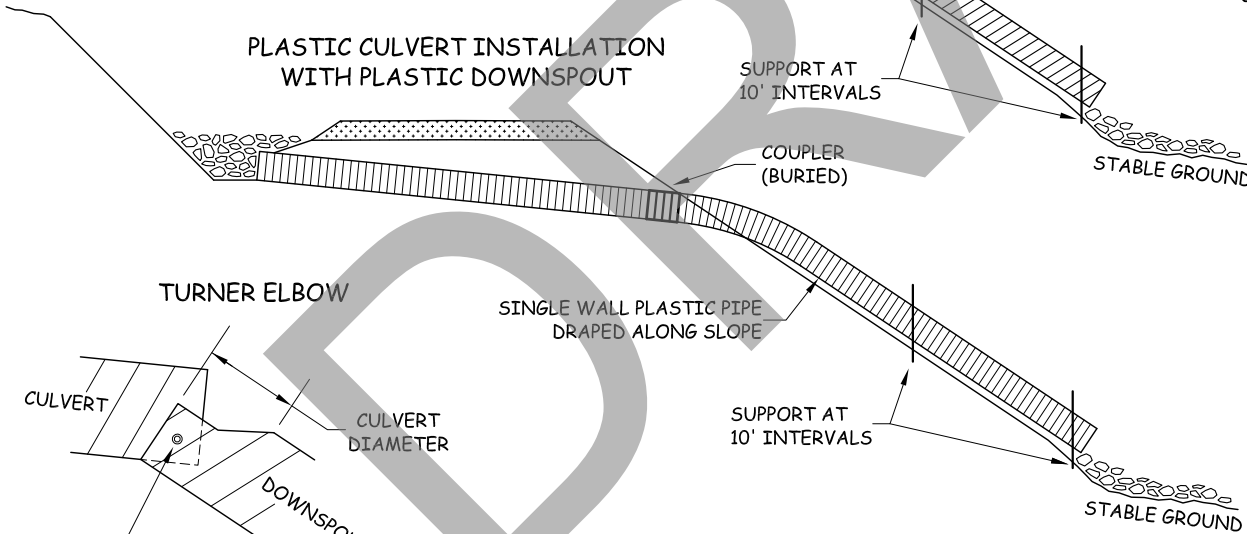

**HEADWALL NOTE:**  
 HEADWALL TO BE CONSTRUCTED OF IMPERVIOUS MATERIAL THAT WILL RESIST EROSION AND ARMORED WITH RIPRAP QUANTITY SPECIFIED IN ROAD PLAN.

CONTRACT #	PROJECT	SHEET
30-093860	STILLY REVISITED	32 OF 33



# PIT DEVELOPMENT PLAN

## OCEANVIEW PIT

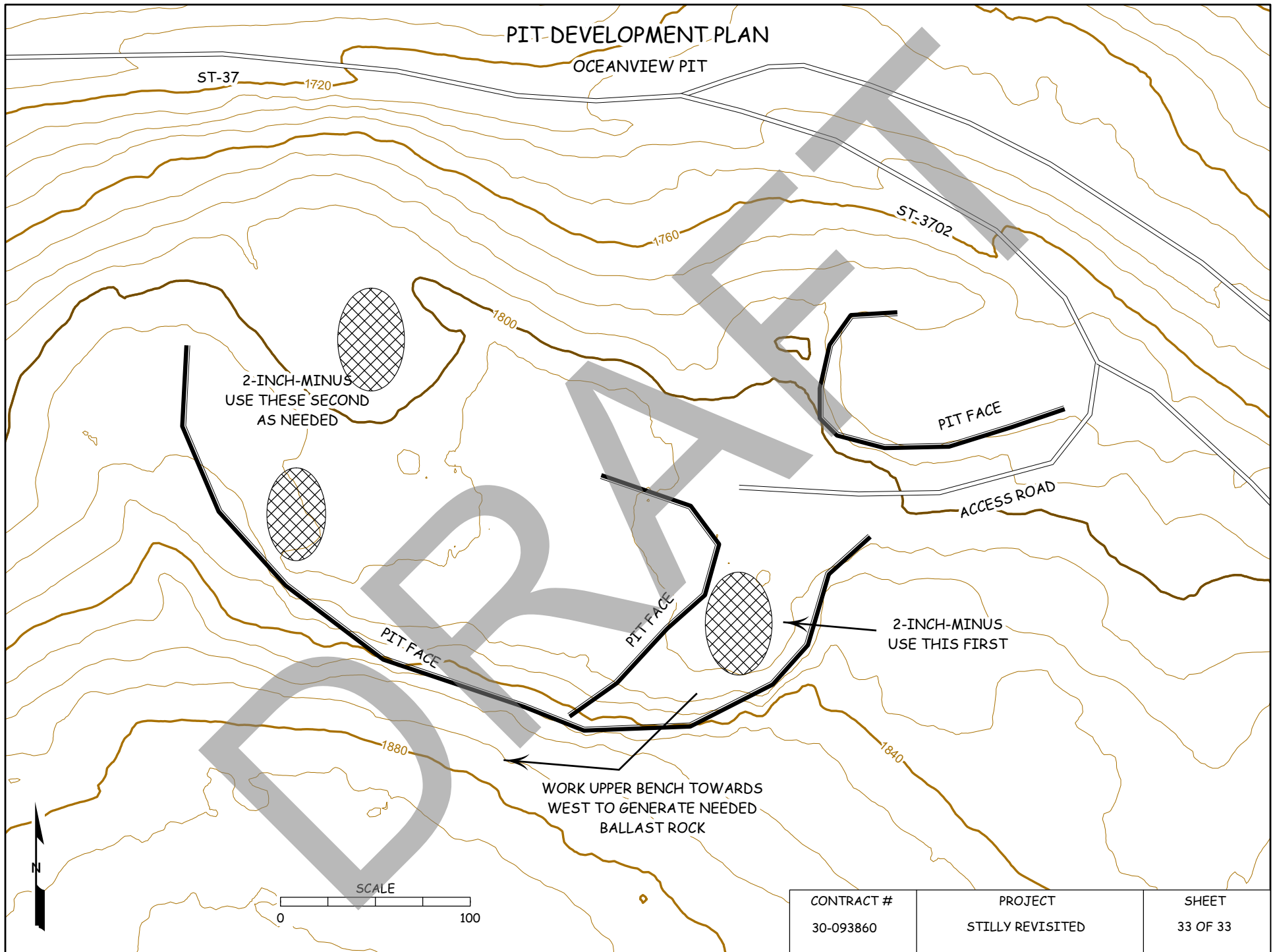

2-INCH-MINUS  
USE THESE SECOND  
AS NEEDED

PIT FACE

ACCESS ROAD

2-INCH-MINUS  
USE THIS FIRST

PIT FACE

PIT FACE

WORK UPPER BENCH TOWARDS  
WEST TO GENERATE NEEDED  
BALLAST ROCK

SCALE

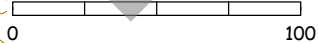

CONTRACT #  
30-093860

PROJECT  
STILLY REVISITED

SHEET  
33 OF 33

# SUMMARY - Road Development Costs

REGION: NW

DISTRICT: Clear Lake

SALE/PROJECT NAME: STILLY REVISITED

CONTRACT #: 30-093860

ROAD NUMBERS:	ST-36, ST-37, ST-3702, ST-3705, ST-3710	ST-37, ST-3702	ST-ML, ST-29, ST-37, ST-3702
ROAD STANDARD:	Construction	Reconstruction	Pre and Post Haul Maintenance
NUMBER OF STATIONS:	56.86	26.14	238.90
CLEARING & GRUBBING:	\$32,365	\$3,973	\$0
EXCAVATION & FILL:	\$63,726	\$9,087	\$0
MISC. MAINTENANCE:	\$0	\$0	\$23,123
ROAD ROCK:	\$104,110	\$22,861	\$25,375
ROCK STOCKPILE PROD:	\$0	\$0	\$0
CULVERTS & FABRIC:	\$16,491	\$7,680	\$0
STRUCTURES:	\$0	\$0	\$0
MOBILIZATION:	\$1,814	\$1,814	\$1,336
TOTAL COSTS:	\$218,506	\$45,415	\$49,834
COST PER STATION:	\$3,843	\$1,737	\$209
ROAD DEACTIVATION & ABANDONMENT COSTS:		\$1,308	
<b>TOTAL (All Roads) =</b>			<b>\$315,063</b>
<b>ESTIMATED PRECRUISE SALE VOLUME MBF =</b>			<b>6650</b>
<b>ESTIMATED TOTAL \$/MBF =</b>			<b>\$47.38</b>

Compiled by: J. Westra

Date: 8/17/2023